

Service Manual

AV Control Stereo Receiver

Receiver

SA-AX710

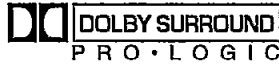

Manufactured under license from Dolby Laboratories Licensing Corporation.
DOLBY, the double-D symbol and "PRO LOGIC" are trademarks of Dolby Laboratories Licensing Corporation.

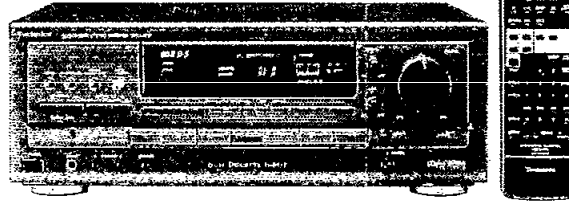

Colour
(K) Black Type

Areas
(E) Europe.
(EB) Great Britain.
(EG) Germany and Italy.

Specifications

FM TUNER SECTION

Frequency range	87.50 – 108.00 MHz
Sensitivity	
S/N 30 dB	1.5 μ V/75 Ω
S/N 26 dB	1.3 μ V/75 Ω
S/N 20 dB	1.2 μ V/75 Ω
IHF usable sensitivity (IHF'58)	1.5 μ V/75 Ω
IHF 46 dB stereo quieting sensitivity	22 μ V/75 Ω
Total harmonic distortion	
MONO	0.2 %
STEREO	0.3 %
S/N	
MONO	60 dB (75 dB, IHF)
STEREO	58 dB (71 dB, IHF)
Frequency response	20 Hz – 15 kHz (+1 dB, -2 dB)
Alternate channel selectivity \pm 400 kHz	60 dB
Capture ratio	1 dB
Image rejection at 98 MHz	40 dB
IF rejection at 98 MHz	70 dB
Spurious response rejection at 98 MHz	70 dB
AM suppression	50 dB
Stereo separation	
1 kHz	40 dB
Carrier leak	
19 kHz	-30 dB (-35 dB, IHF)
38 kHz	-50 dB (-55 dB, IHF)
Channel balance (250 Hz – 6.3 kHz)	\pm 1.5 dB
Limiting point	1.2 μ V
Bandwidth	
IF amplifier	180 kHz
FM demodulator	1000 kHz
Antenna terminal	75 Ω (unbalanced)

AM TUNER SECTION

Frequency range	
AM	522 kHz – 1611 kHz (9 kHz steps) 530 kHz – 1620 kHz (10 kHz steps)
Sensitivity	20 μ V, 330 μ V/m
Selectivity (at 999 kHz)	55 dB
Image rejection (at 999 kHz)	40 dB
IF rejection (at 999 kHz)	55 dB

VIDEO SECTION

Output voltage at 1V input (unbalanced)	1 \pm 0.1 Vp-p
Maximum input voltage	1.5 Vp-p
Input/output impedance	75 Ω (unbalanced)

AMPLIFIER SECTION

Power output [at 240V for (EB) area]	
DIN 1 kHz (T.H.D. 1 %)	2 \times 100 W (4 Ω)
20 Hz – 20kHz continuous power output both channels driven	2 \times 65 W (8 Ω)

Total harmonic distortion	
rated power at 20 Hz – 20 kHz	0.05 % (8 Ω)
half power at 1 kHz	0.03 % (8 Ω)
Power output at the Dolby Pro Logic operation	
DIN 1 kHz (T.H.D. 1 %)	
Front	2 \times 60 W (4 Ω)
Center	60 W (8 Ω)
Surround	2 \times 60 W (8 Ω)
Intermodulation distortion	
rated power at 60 Hz : 7 kHz = 4 : 1, SMPTE	0.5 % (8 Ω)
Power bandwidth	
both channels driven, -3 dB	10 Hz – 40 kHz (8 Ω)
Damping factor	30 (8 Ω)
Load impedance	
Front A or B	4 – 16 Ω
A and B	8 – 16 Ω
Center	8 – 16 Ω
Surround	8 – 16 Ω
Frequency response	
PHONO	RIAA standard curve (30 Hz – 15 kHz) \pm 0.8 dB
CD, TAPE, TV/VCR2, VCR1, DVD	10 Hz – 40 kHz, \pm 3 dB
Input sensitivity and impedance	
PHONO	3 mV/47 k Ω
CD, TAPE, TV/VCR2, VCR1, DVD	200 mV/22 k Ω
S/N at rated power (8 Ω)	
PHONO	70 dB (IHF, A : 80 dB)
CD, TAPE, TV/VCR2, VCR1, DVD	75 dB (IHF, A : 85 dB)
Tone controls	
BASS	50 Hz, +10 to -10 dB
TREBLE	20 kHz, +10 to -10 dB
Output voltage	
TAPE REC (OUT), VCR1 out	200 mV
Channel balance (250 Hz – 6.3 kHz)	\pm 1 dB
Channel separation	55 dB
Loudness control (volume at -30 dB)	50 Hz, +9 dB
Headphones output level and impedance	430 mV/330 Ω
Subwoofer frequency response	7 Hz – 100 Hz, \pm 3dB

GENERAL

Power consumption	220 W (In standby condition : 3 W)
Power supply	
For (E) and (EG) areas	AC 230 V, 50 Hz
For (EB) area	AC 230 – 240 V, 50 Hz
Dimensions (W \times H \times D)	430 \times 158 \times 312 mm
Weight	9.6 kg

Notes:

- Specifications are subject to change without notice.
Weight and dimensions are approximate.
- Total harmonic distortion is measured by the digital spectrum analyzer.

WARNING

This service information is designed for experienced repair technicians only and is not designed for use by the general public. It does not contain warnings or cautions to advise non-technical individuals of potential dangers in attempting to service a product. Products powered by electricity should be serviced or repaired only by experienced professional technicians. Any attempt to service or repair the product or products dealt with in this service information by anyone else could result in serious injury or death.

Technics®

© 1997 Matsushita Electric Industrial Co., Ltd.
All rights reserved. Unauthorized copying
and distribution is a violation of law.

Contents

	Page		Page
Accessories	2	Operation Checks and Main Component Replacement Procedures	19 – 23
Before Repair	2	Fan Motor Troubleshooting	24
Protection Circuitry	2	Troubleshooting	25 – 28
Caution for AC Main Lead	3	Schematic Diagram	29 – 42
Front Panel Controls	4	Printed Circuit Board and Wiring Connection Diagram	43 – 50
Equipment Connections	5 – 8	Wiring Connection Diagram	51
Speaker Connections	9, 10	Block Diagram	52 – 58
Basic Operations	11, 12	Replacement Parts List	59 – 64
Enjoying RDS Broadcasts	13, 14	Packaging	64
Enjoying Sound with DOLBY PRO LOGIC	15 – 17	Cabinet Parts Location	65, 66
Enjoying Sound with 6 Channel Discrete	18		

Accessories

- AC power supply cord
[for (E) and (EG) areas]: (RJA0019-2K) .. 1 pc.
- AM loop antenna set
(RSA0010) 1 pc.
- FM indoor antenna
(RSA0007) 1 pc.

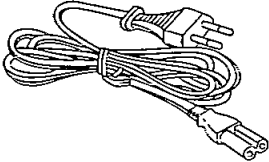

[for (EB) area]: (VJA0733) 1 pc.

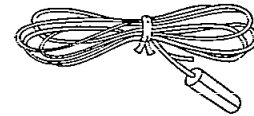
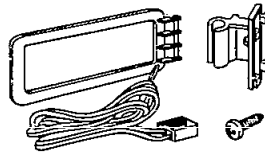
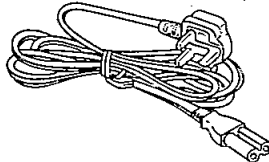

- Batteries
..... 2 pc.
- Remote control transmitter
(RAK-SA750WHP) 1 pc.
- Attachment plug
(SJP9009) 1 pc.

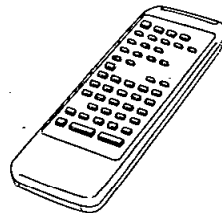
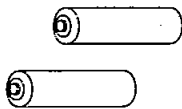

Before Repair

- (1) Turn off the power supply. Using a 10 Ω , 10 W resistor, connect both ends of power supply capacitors (C703, C704, C705, C706) in order to discharge the voltage.
- (2) Before turning the power supply on, after completion of repair, slowly apply the primary voltage by using a power supply voltage controller to make sure that the consumed current at 50 Hz in NO SIGNAL mode should be shown below with respect to supply voltage 230 V or 240 V.

Power supply voltage	AC 230 V	AC 240 V
Consumed current 50 Hz	120 ~ 350 mA	130 ~ 380 mA

Protection Circuitry

The protection circuitry may have operated if either of the following conditions is noticed:

- No sound is heard when the power is switched ON.
- Sound stops during a performance.

The function of this circuitry is to prevent circuitry damage if, for example, the positive and negative speaker connection wires are "shorted", or if speaker systems with an impedance less than the indicated rated impedance of this unit are used.

If this occurs, follow the procedure outlined below:

1. Switch OFF the power.
2. Determine the cause of the problem and correct it.
3. Switch ON the power once again.

Note:

When the protection circuitry functions, the unit will not operate unless the power is first switched OFF and then ON again.

■ Caution for AC Main Lead



("EB" area code model only)

For your safety, please read the following text carefully.

This appliance is supplied with a moulded three pin mains plug for your safety and convenience.

A 5-ampere fuse is fitted in this plug.

Should the fuse need to be replaced please ensure that the replacement fuse has a rating of 5-ampere and that it is approved by ASTA or BSI to BS1362.

Check for the ASTA mark  or the BSI mark  on the body of the fuse.

If the plug contains a removable fuse cover you must ensure that it is refitted when the fuse is replaced.

If you lose the fuse cover the plug must not be used until a replacement cover is obtained.

A replacement fuse cover can be purchased from your local dealer.

CAUTION!

IF THE FITTED MOULDED PLUG IS UNSUITABLE FOR THE SOCKET OUTLET IN YOUR HOME THEN THE FUSE SHOULD BE REMOVED AND THE PLUG CUT OFF AND DISPOSED OF SAFELY. THERE IS A DANGER OF SEVERE ELECTRICAL SHOCK IF THE CUT OFF PLUG IS INSERTED INTO ANY 13-AMPERE SOCKET.

If a new plug is to be fitted please observe the wiring code as shown below.

If in any doubt please consult a qualified electrician.

IMPORTANT

The wires in this mains lead are coloured in accordance with the following code:

Blue: Neutral, Brown: Live.

As these colours may not correspond with the coloured markings identifying the terminals in your plug, proceed as follows:

The wire which is coloured Blue must be connected to the terminal which is marked with the letter N coloured Black or Blue.

The wire which is coloured Brown must be connected to the terminal which is marked with letter L or coloured Brown or Red.

WARNING: DO NOT CONNECT EITHER WIRE TO THE EARTH TERMINAL WHICH IS MARKED WITH LETTER E, BY THE EARTH SYMBOL  OR COLOURED GREEN OR GREEN/YELLOW.

THIS PLUG IS NOT WATERPROOF—KEEP DRY.

Before use

Remove the connector cover.

How to replace the fuse

The location of the fuse differ according to the type of AC mains plug (figures A and B). Confirm the AC mains plug fitted and follow the instructions below.

Illustrations may differ from actual AC mains plug.

1. Open the fuse cover with a screwdriver.

Figure A

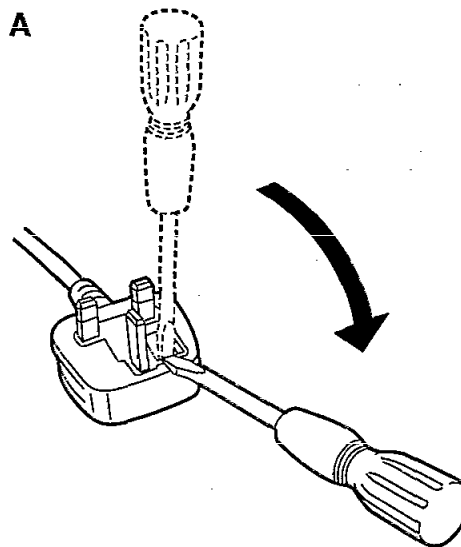
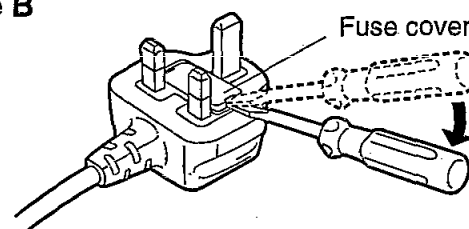

Figure B



2. Replace the fuse and close or attach the fuse cover.

Figure A

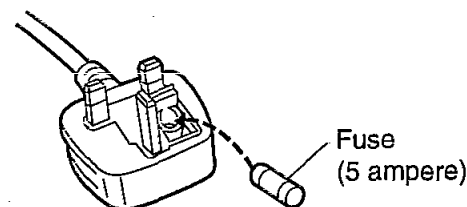
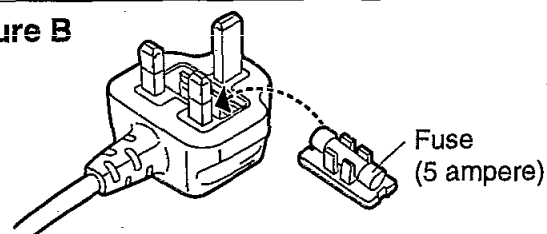
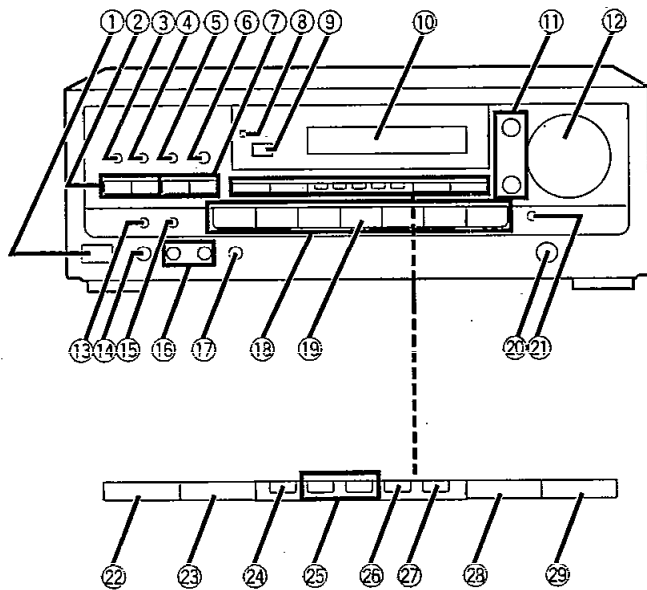

Figure B



■ Front Panel Controls



- ① **Power "STANDBY /ON" switch (POWER, STANDBY /ON)**
Press to switch the unit from on to standby mode or vice versa. In standby mode, the unit is still consuming a small amount of power.
- ② **Tuning buttons (TUNING)**
- ③ **Band select button (BAND)**
- ④ **FM mode select button (FM AUTO/MONO)**
- ⑤ **Memory button (MEMORY)**
- ⑥ **Help/reset button (-HELP -RESET)**
- ⑦ **Preset channel buttons (PRESET)**
- ⑧ **"STANDBY" indicator (STANDBY)**
When the unit is connected to the AC mains supply, this indicator lights up in standby mode and goes out when the unit is turned on.
- ⑨ **Remote control signal sensor (SENSOR)**
- ⑩ **Display**
- ⑪ **Tone controls (BASS, TREBLE)**
- ⑫ **Volume control (VOLUME)**
- ⑬ **Sleep timer button (SLEEP)**
- ⑭ **Headphones jack (PHONES)**
- ⑮ **6ch discrete input select button (6CH DISCRETE INPUT)**
- ⑯ **Speakers select buttons (SPEAKERS A, B)**
- ⑰ **Loudness ON/OFF button (LOUDNESS)**
- ⑱ **Input select buttons**
- ⑲ **Tape monitor button (TAPE MONITOR)**
- ⑳ **Balance control (BALANCE)**
- ㉑ **Muting button (MUTING)**
- ㉒ **DOLBY PRO LOGIC OFF ON button (OFF/ON)**
- ㉓ **DOLBY PRO LOGIC mode select button (PRO LOGIC)**
- ㉔ **RDS display mode select button (DISPLAY MODE)**
- ㉕ **PTY select buttons (PTY SELECT)**
- ㉖ **EON ON/OFF button (EON)**
- ㉗ **PTY search button (SEARCH)**
- ㉘ **Delay time adjust button (DELAY TIME)**
- ㉙ **Center mode select button (CENTER MODE)**

Equipment Connections

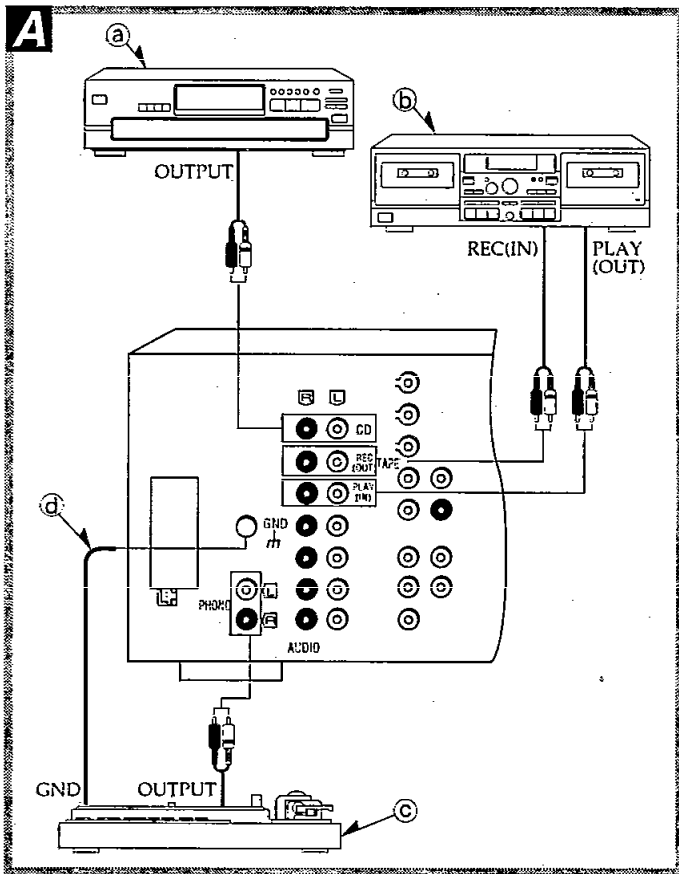

Make sure that the power supply for all components has been turned off before making any connections.

To connect equipment, refer to the appropriate operating instructions.

Note

Do not place books, etc., on top of this unit or block the heat radiation vents in any way.

Stereo connection cable (not included) (L) White (R) Red

Video connection cable (not included)

Connecting audio equipment

- Ⓐ CD changer (or CD player) (not included)
- Ⓑ Tape deck (not included)
- Ⓒ Turntable (not included)
- Ⓓ Only for turntable with ground terminal

Connecting video equipment

- Ⓐ Laser disc player (not included)
- Ⓑ TV (not included)
- Ⓒ VCR (not included)

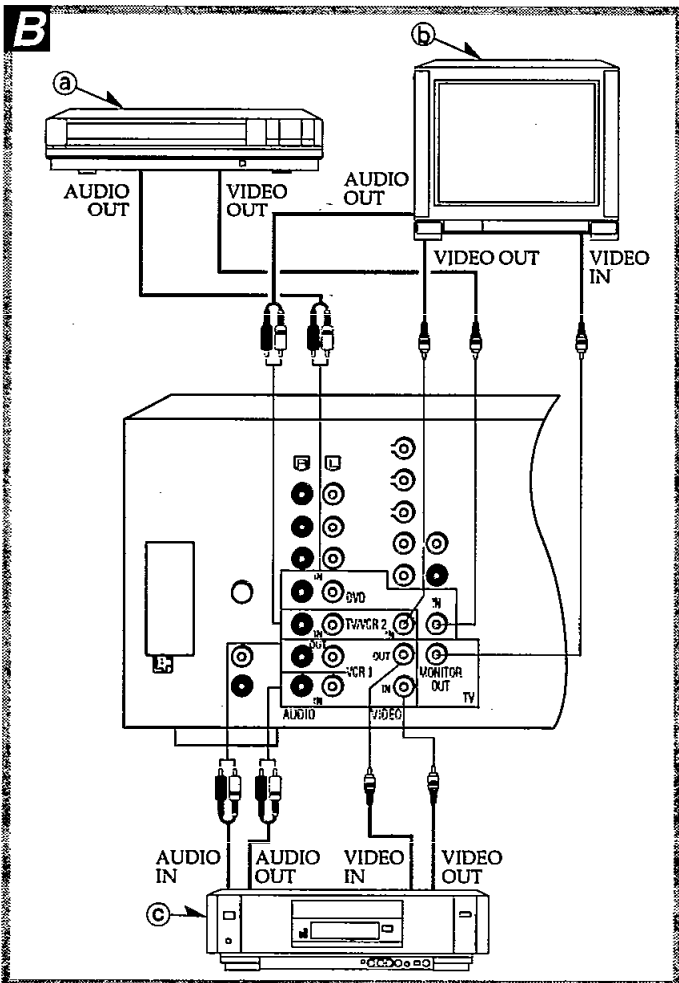

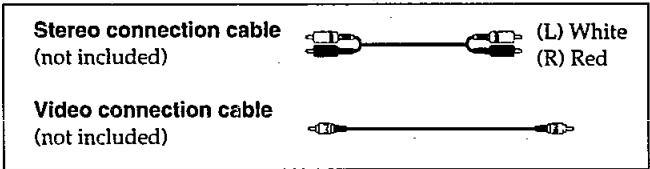
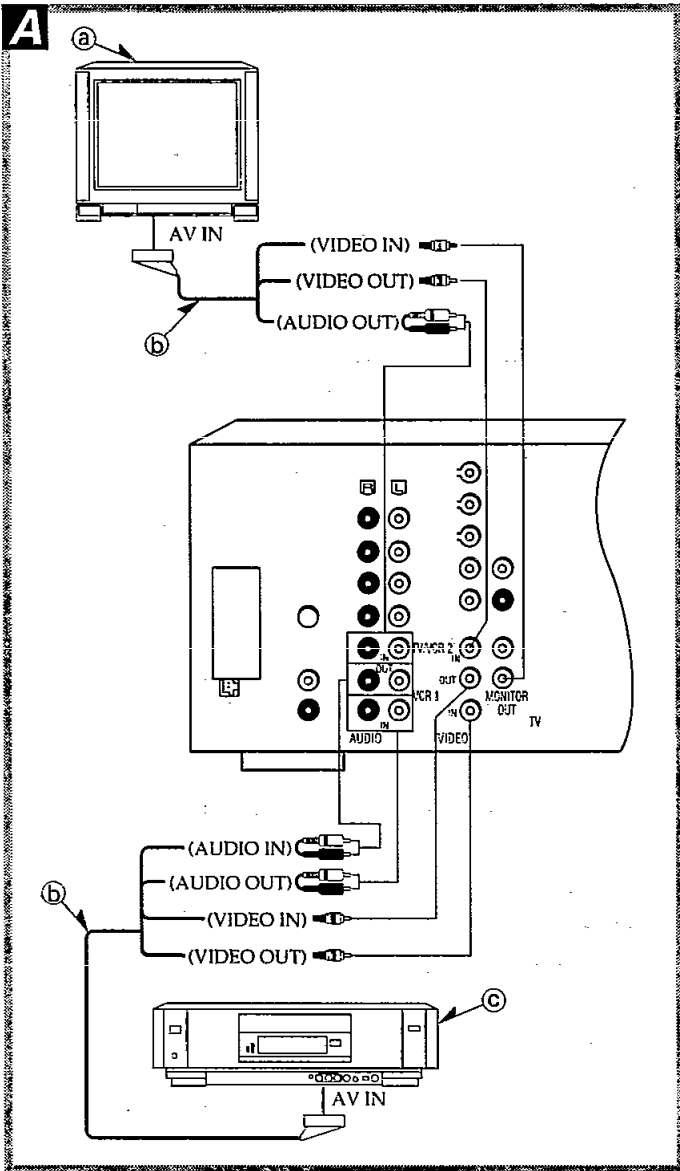

To connect a video equipment with 21 pin terminal **A**

- ⓐ TV (not included)
- ⓑ 21 pin scart cables (not included)
- ⓒ VCR (not included)

To connect a second VCR **B**

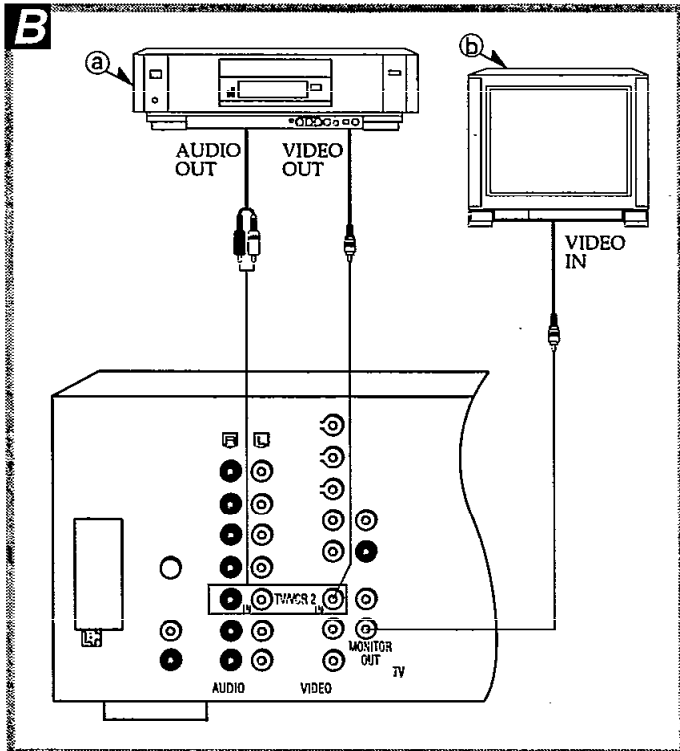

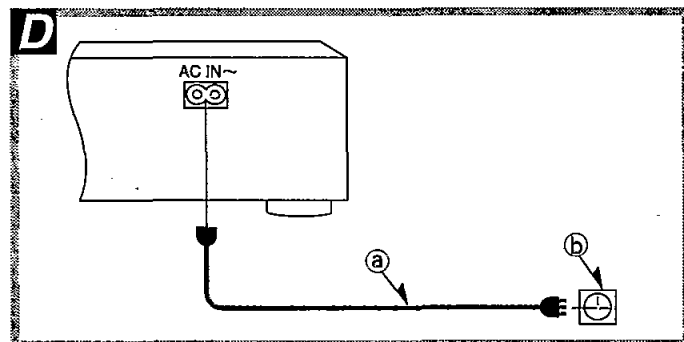
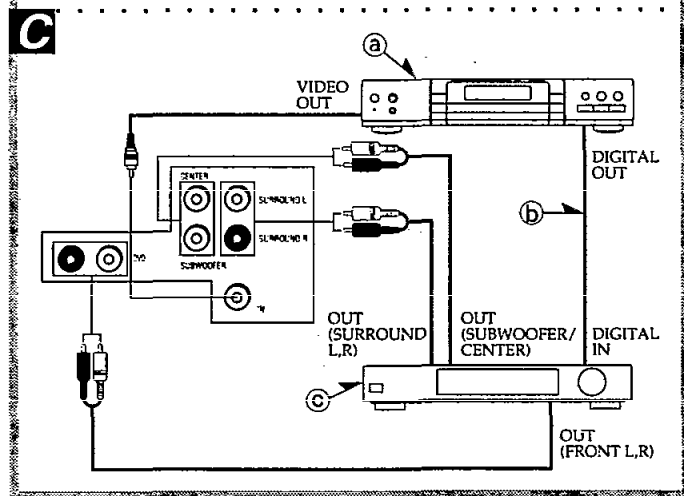
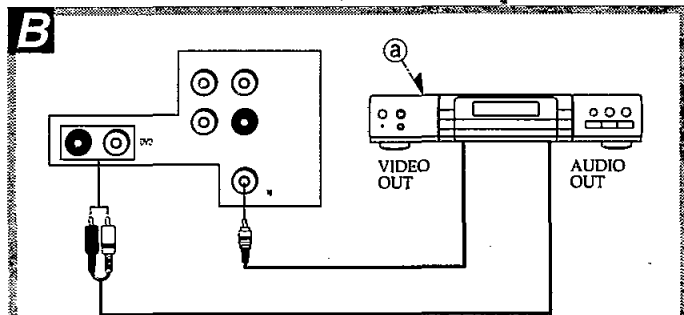
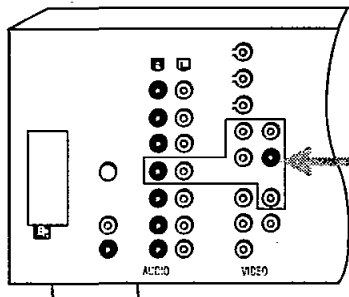
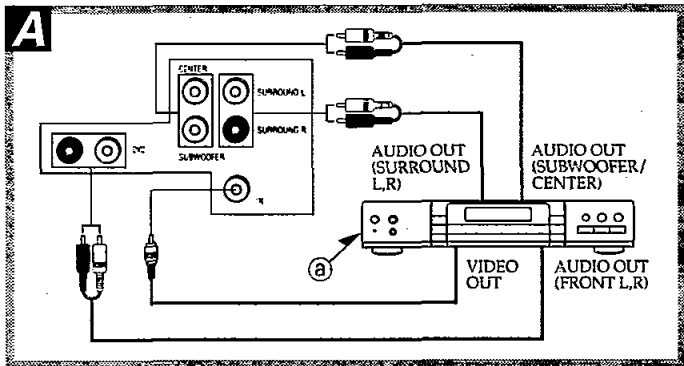

Stereo connection cable (not included)

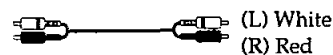

Video connection cable (not included)

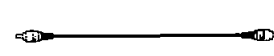

Connecting a DVD player

Connecting a DVD player with 6 channel discrete output **A**

Ⓐ DVD player (not included)

Connecting a DVD player with 2 channel output **B**

Ⓐ DVD player (not included)

You can enjoy 6 channel discrete sound by making these connections. **C**

- Ⓐ DVD player (not included)
- Ⓑ Optical digital cable (not included)
- Ⓒ AC-3 decoder (not included)

AC power supply cord **D**

Connect this mains lead after all other cables and cords are connected.

BE SURE TO READ THE CAUTION FOR THE AC MAINS LEAD ON PAGE 3 BEFORE THE FOLLOWING CONNECTION. [(EB) area code model only]

- Ⓐ AC mains lead (included)
- Ⓑ Household AC outlet

Insertion of Connector

Even when the connector is perfectly inserted, depending on the type of inlet used, the front part of the connector juts out as shown in the drawing. However there is no problem using the unit.

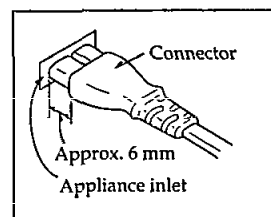

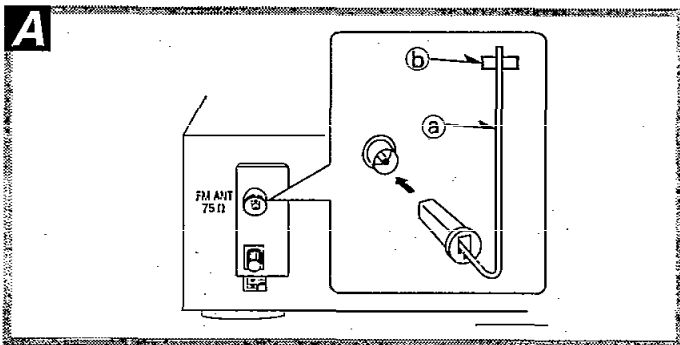

FM indoor antenna (included) A

This antenna is normally sufficient for reception of FM broadcasts.

Ⓐ FM indoor antenna (included)

Ⓑ Tape

Attach to a wall (using a tape) facing in the direction of best reception.

For best reception sound quality

An FM outdoor antenna is recommended.

AM loop antenna (included) B

This antenna is normally sufficient for reception of AM broadcasts. Install the AM antenna holder (included) at the rear panel of this unit and then attach the AM loop antenna to the AM antenna holder (facing in the direction of best reception).

Ⓐ AM loop antenna (included)

Pay attention to the following points when mounting the antenna.

- Do not mount it horizontally (doing so will impair reception).
- Do not mount it close to power supply cords, speaker wires or metal surfaces (doing so will result in noise).
- Do not mount it close to a tape deck. When the tape deck is being used, chirping or beeping sounds may result.

When mounting the antenna to a column, a wall or rack C

Mount it vertically.

Ⓐ Screw (included)

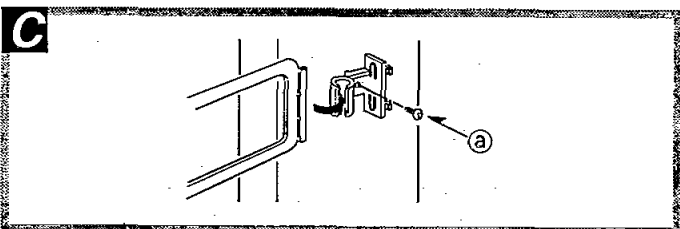
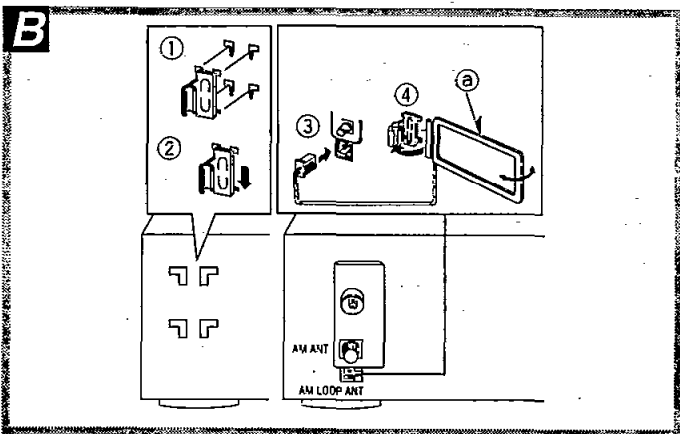

FM outdoor antenna (not included) D

The outdoor antenna should be used when using the unit in mountainous areas or in spaces enclosed by reinforced concrete where the FM indoor antenna (included) does not provide satisfactory reception.

Disconnect the FM indoor antenna if an FM outdoor antenna is installed.

Ⓐ FM outdoor antenna (not included)

Ⓑ 75 Ω coaxial cable (not included)

Ⓒ Attachment plug (included)

Note

An outdoor antenna should be installed by a qualified technician only.

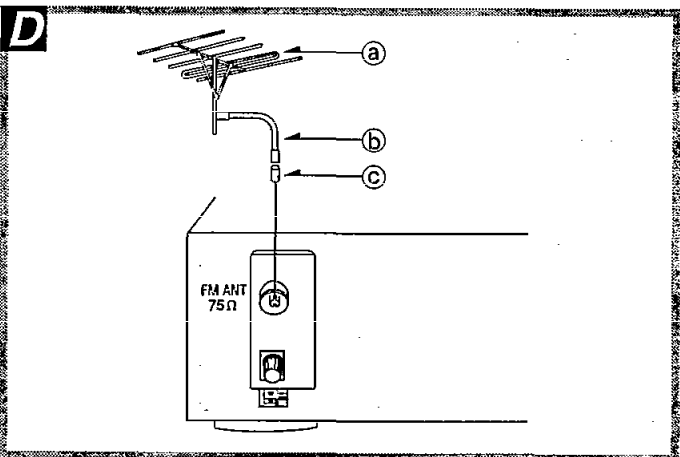

AM outdoor antenna (not included) E

The outdoor antenna should be used when using the unit in mountainous areas or in spaces enclosed by reinforced concrete where the AM loop antenna (included) does not provide satisfactory reception.

Ⓐ AM outdoor antenna (not included)

Ⓑ AM loop antenna (included)

Stretch 5 to 12 m of vinyl-covered wire horizontally across a window frame or other convenient location, keeping it as high as possible from the ground.

When the unit is not in use, disconnect the outdoor antenna to prevent possible damage that may be caused by lightning. Never use an outdoor antenna during an electrical storm.

Note

Be sure to connect the AM loop antenna even when an AM outdoor antenna is used.

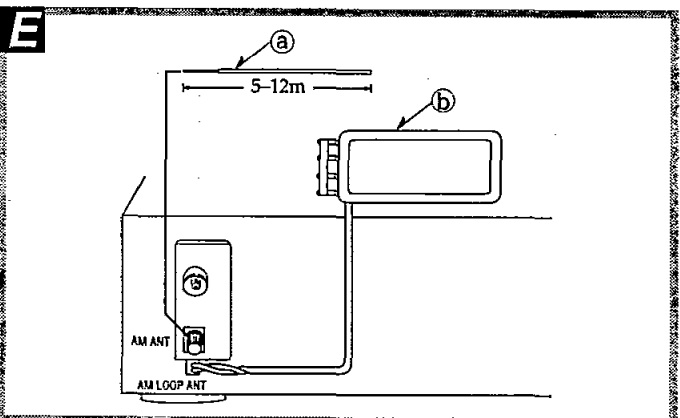

Speaker Connections

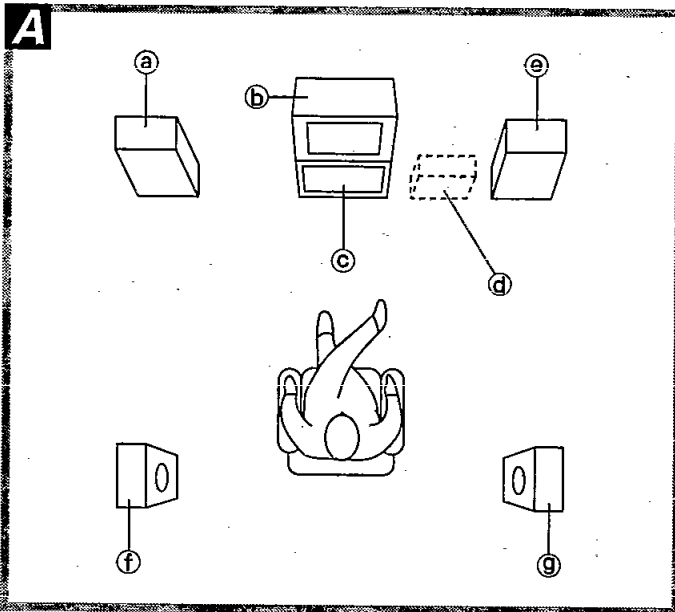

Placement of speakers

- Ⓐ Front speaker (Left) (not included)
- Ⓑ TV (not included)
- Ⓒ Center speaker (not included)
- Ⓓ Subwoofer (not included)
- Ⓔ Front speaker (Right) (not included)
- Ⓕ Surround speaker (Left) (not included)
- Ⓖ Surround speaker (Right) (not included)

For front speakers

Place the front left/right speakers at both the left and right sides of the TV at seated ear height so that there is good coherency between the picture and sound.

For center speaker

Place the center speaker underneath or above the center of the TV. Aim the speaker such that it is pointed at the seating area.

For surround speakers

Place the surround speakers on the side of or slightly behind the listener, and about one meter higher than ear level.

For subwoofer

The subwoofer can be placed in any position as long as it is at a reasonable distance from the TV.

Note that some experimentation in placement of the subwoofer can yield smoothest low frequency performance. Placement near a corner can increase the apparent output level, but can result in unnatural bass.

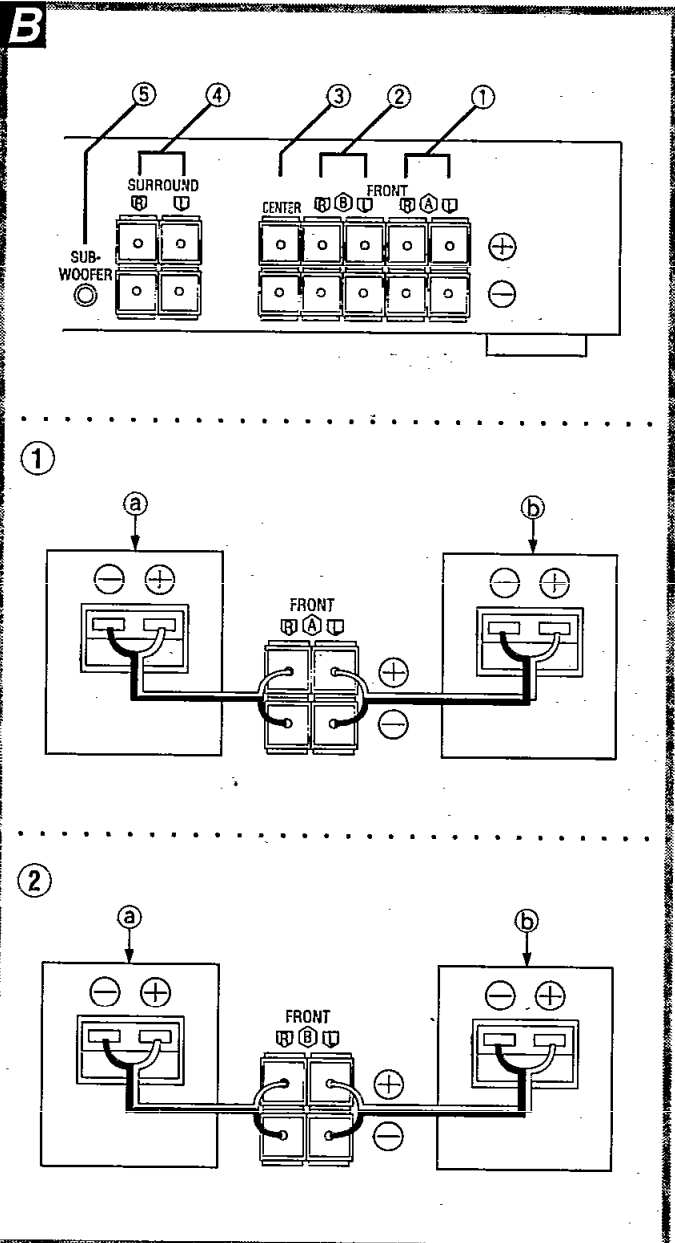

Connecting speakers

Speaker cable
(not included)



① Front "A" speakers

- Ⓐ Right speaker (not included)
- Ⓑ Left speaker (not included)

② Front "B" speakers

For connection to a second pair of speakers.

- Ⓐ Right speaker (not included)
- Ⓑ Left speaker (not included)

Speaker impedance: A or B 4-16 Ω
A and B 8-16 Ω

(Continued on next page)

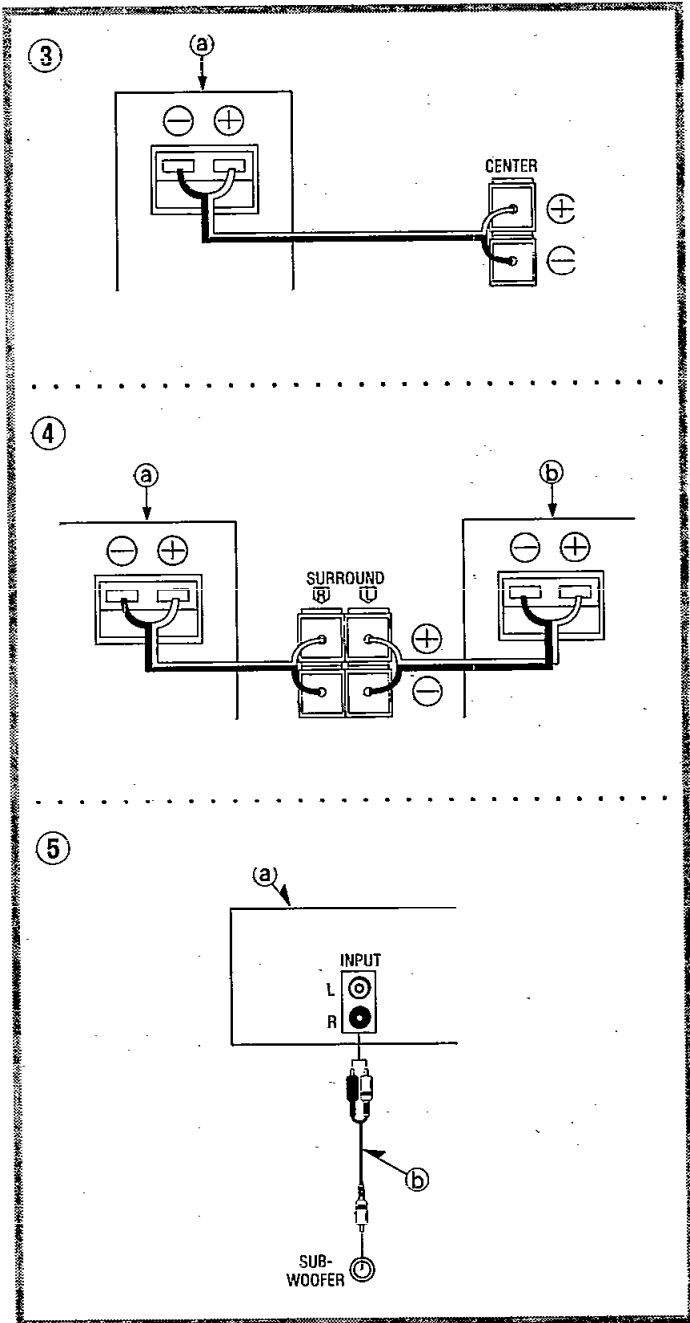

3 Center speaker

- (a) Center speaker (not included)
- Speaker impedance: 8-16 Ω

4 Surround speakers

- (a) Right speaker (not included)
- (b) Left speaker (not included)

Note

1. Before sound can be heard, both surround speakers must be connected.
2. Do not connect the surround speakers to the front speaker terminals. The surround speakers may be damaged if connected to the front terminals.

Speaker impedance: 8-16 Ω

5 Subwoofer

- (a) Subwoofer with built in amplifier (not included)
- (b) Monaural-Stereo converter (not included)

Note

This receiver has no amplifier section designed especially for the subwoofer.

For your reference

Subwoofer can be connected in both the below ways.

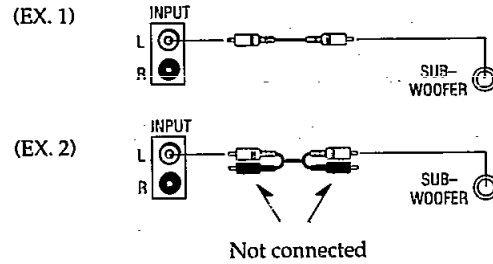

To connect a subwoofer which does not have a built-in amplifier

Connect an optional amplifier to the "SUBWOOFER" terminals of this unit and then connect a subwoofer to the speaker terminals of the amplifier.

Connecting the speaker cables

Note

To prevent damage to circuitry, never short-circuit positive (+) and negative (-) speaker wires.

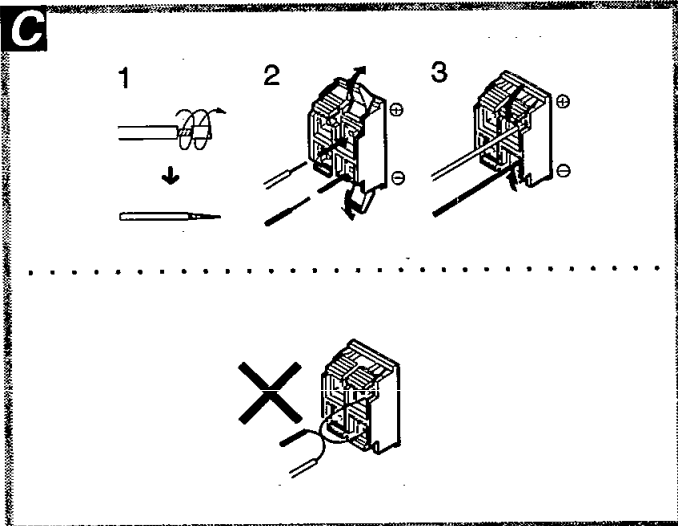

Basic Operations

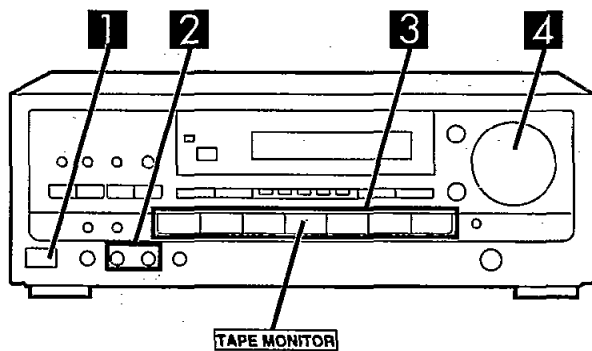

Before operation, set VOLUME to the "MIN" position.

- 1** Press **POWER**.
- 2** Press **A** and/or **B** to select the speakers system(s) to be used.

A and B refer to the speaker terminals at the rear of the unit.

If the button is pressed once more, the indicator will switch off and no sound will be heard from the speakers.

- 3** Press to select the desired source and start the desired source.
(Refer to the appropriate operating instructions for details.)

VCR 1: To watch video tapes (VCR 1)

TV/VCR 2: To watch TV or video tapes (VCR 2)

DVD: To watch DVD

TAPE MONITOR: To listen to cassette tapes. (The tape monitor indicator will light up.)

CD: To listen to compact discs

TUNER: To listen to radio broadcast

PHONO: To listen to phono discs

Note

To watch a video (or DVD) or the TV, set the TV to either the TV mode or VIDEO mode as indicated below.

- **To enjoy videos (or DVD)**

Set it to VIDEO mode.

- **To watch TV**

Set it to TV mode.

- 4** Turn **VOLUME** to adjust the volume level.

After listening is finished

Be sure to reduce the volume level, and switch the power to the standby condition by pressing **POWER**.

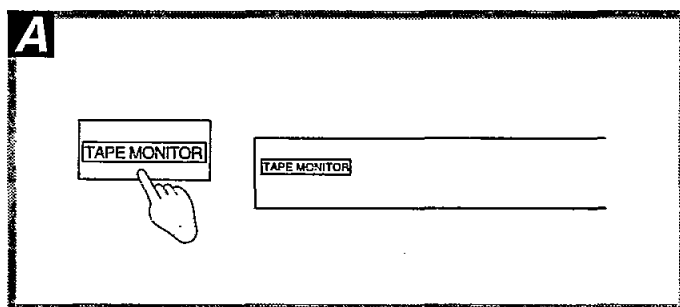
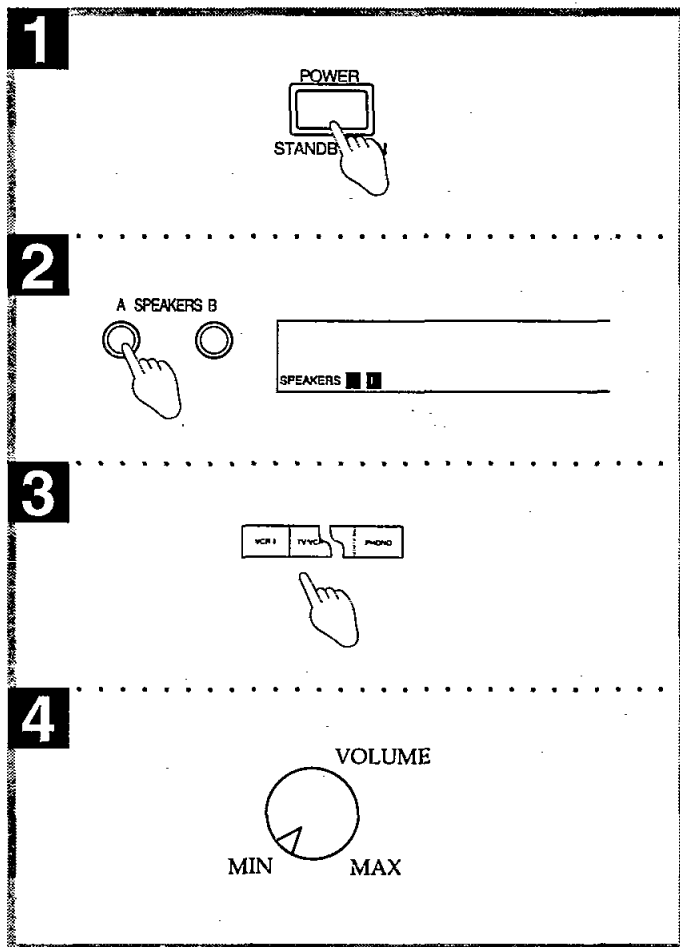

When the tape monitor indicator is lit or flashing

This indicates that the tape monitor function of this unit is ON.

To listen to sources other than a tape, be sure to press **TAPE MONITOR** and check the indicator goes out.

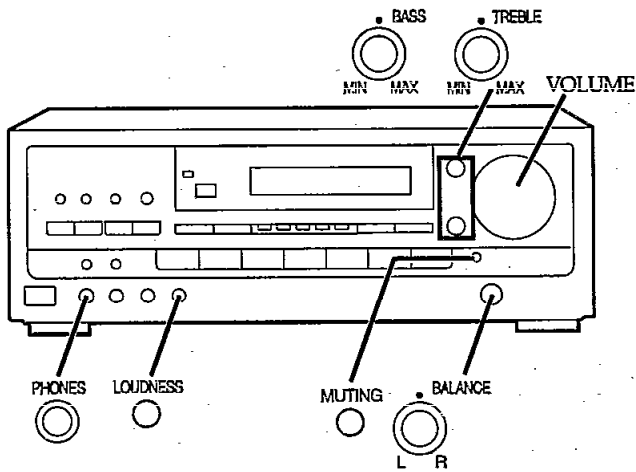

To adjust the tone quality A

- Ⓐ Turn BASS to adjust the low frequency sound.
- Ⓑ Turn TREBLE to adjust the high frequency sound.

To adjust the sound balance B

Turn BALANCE to adjust the left/right sound balance.

To mute the sound level C

Press MUTING.
The message "MUTING ON NOW" runs repeatedly from right to left across the display as long as the muting function is on.

Press once again to return to the previous volume level.

Note

When the receiver is turned off, the muting operation will be automatically cancelled.

To listen through headphones D

- ① Use volume to reduce the volume level.
- ② Connect the headphones (not included).
Plug type: 6.3mm stereo
- ③ Use VOLUME to adjust the volume level.

If you do not want sound from the speakers, press SPEAKERS button(s) and check the speaker indicator(s) goes out.
If a subwoofer is connected to your system, turn off power to it (or the subwoofer amp you are using) or lower the volume to the minimum level.

Note

Avoid listening for prolonged periods of time to prevent hearing damage.

To correct sound in case of low volume E

This button balances low volume sounds by boosting bass sound pressure.

Press LOUDNESS.

The message "LOUDNESS" will appear on the display, followed shortly thereafter by the current setting "OFF". (①-②)
Pressing the button again within 4 seconds will turn loudness control ON. When ON, "■" indication will light up in the display. (③-④)
To return to the previous condition, press once again, then "■" indication turn off.

A

Ⓐ

Ⓑ

B

C

MUTING ON NOW

D

①

② PHONES

E

① LOUDNESS

② OFF

③ ON

④

■ Enjoying RDS Broadcasts

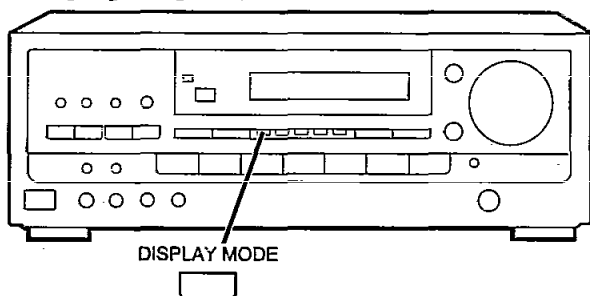

DISPLAY MODE

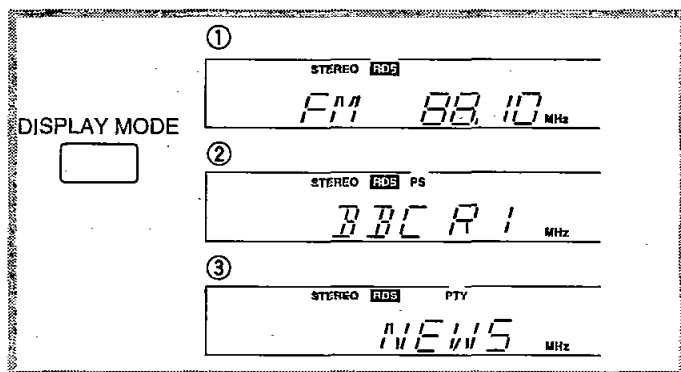

RDS (Radio Data System) is a multiplex broadcasting system which adds a variety of message signals to the audio signals of FM broadcasts.

This unit can utilize the following signals among the various RDS signals.

- **PI** (Program identification)
Program identification signal consisting of a program code
- **PS** (Program service name)
Name of the broadcast station
- **PTY** (Program type)
Identification signal for program types such as news and sport
- **EON** (Enhanced other networks)
RDS information provided on cross-referenced program services

Note

"PTY" and "EON" may not be available in some areas.
(Future function)

To change the display mode (PS/PTY display)

Carry out this operation while the FM broadcast being received provides the RDS service. ("RDS" will light up.)

When this unit receives a PS signal in an RDS broadcast, the name of the broadcast station can be shown on the display.

Furthermore, while the PTY signal is being received, the name of the type of program currently being broadcast can be shown on the display.

Press DISPLAY MODE.

Each time you press the button, the display will change as follows.

① frequency display → ② PS display → ③ PTY display

Note

1. If the FM broadcast being received does not provide the RDS service, the frequency will remain on the display in displays ② and ③.
2. If a PTY signal is not being received, "NO PTY" will be displayed in display ③ for a moment and will then change to the frequency.

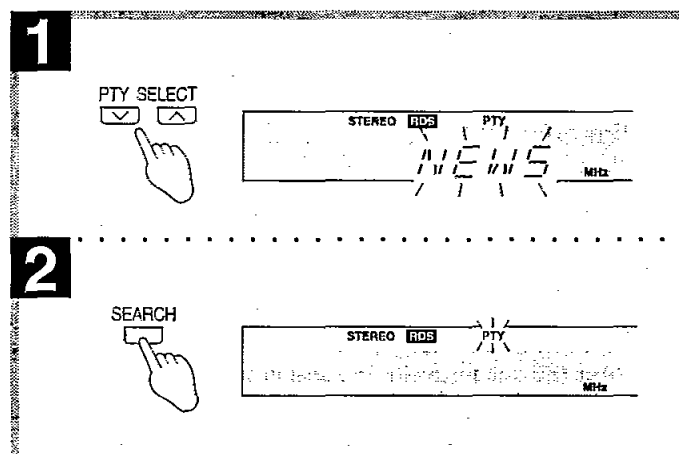
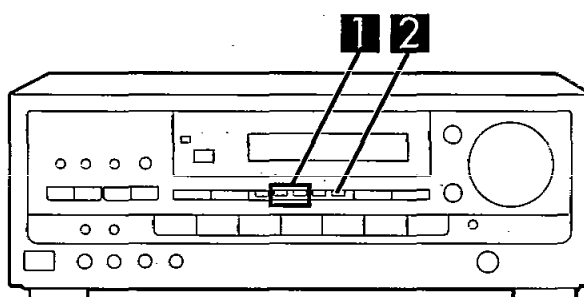

To listen to a program of a particular type, such as news or sport (PTY search/EON tuning)

The PTY search and EON tuning are carried out with respect to FM broadcast stations that have preset into the memory. Make sure that "Memory Presettings" on page 15 or 16 have been completed before carrying out these operations.

PTY search

Carry out this operation while listening to an FM broadcast.

When you wish to listen to a particular type of program, a program of that type can be searched.

- 1** Press **PTY SELECT** (∨) or (∧) to select the desired program type.

Each time you press these buttons, the PTY display will change in sequence.

- 2** While PTY display is flashing (approx. 10 seconds) Press **SEARCH**.

The PTY search will begin. ("PTY" will flash.)

When the desired type of program is located:

The receiver will switch to the preset channel it just found and will display the broadcast frequency. (If the PS or PTY display was displayed when the search started, the receiver will switch back to the original display after displaying the frequency of the found station.) If you start the PTY search again, the receiver will start searching for another program from that point.

If the desired type of program is not found:

"NO PTY" will be displayed for a moment and then the receiver will return to the original display. (If the PS or PTY display was displayed when the search started, the receiver will display the frequency for about 3 seconds before returning to the original display.)

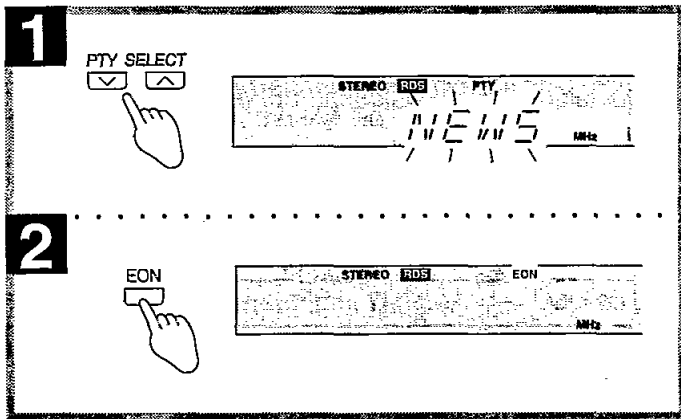
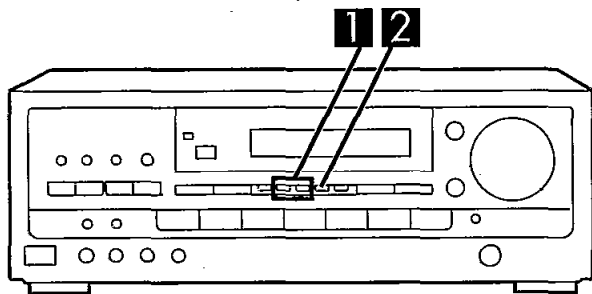

EON tuning

If the broadcast you are receiving is sending EON signals, you can pick up other information from cross-referenced program services such as PS and PTY. This receiver makes use of PTY signals to let you get more out of it.

Carry out this operation while the FM broadcast being received provides the RDS service. ("RDS" will light up.)

- 1** Press PTY SELECT (V) or (^) to select the desired program type.
Each time you press these buttons, the PTY display will change in sequence.
- 2** While PTY display is flashing (approx. 10 seconds) Press EON.
("EON" will light up.)

The receiver will switch over to the type of program you selected or it will go on reception standby and wait until a program of that type starts, at which time it will switch over automatically.

Note

Be aware of the fact that you will turn EON tuning OFF if, while the receiver is on reception standby, you operate the tuner, change the input source or turn the unit OFF.

When "NO EON" is displayed:

It means the broadcast you are presently receiving does not provide EON services.

To check the program type while on reception standby:

Press either PTY SELECT (V) or (^).

The program type last selected will be displayed for approximately 2 seconds. ("EON" will flash.)

Be careful however. If you press one of the buttons again while the program type is being displayed, you will turn EON tuning OFF.

To cancel EON tuning:

Press EON.

"EON" will go out.

About the PTY display

There are a total of 15 PTY displays on this unit. The display changes in order each time the PTY SELECT (V) or (^) is pressed. The table below shows the order in which the display changes, and also gives an explanation of each display.

Display	Explanation
NEWS	Short accounts of facts, events and publicly expressed views, reportage and actuality.
AFFAIRS	Topical program expanding or enlarging upon the news, generally in different presentation style or concept, including documentary debate, or analysis.
INFO	Program whose purpose is to impart advice in the widest sense, including meteorological reports and forecasts, consumer affairs, medical help, etc.
SPORT	Program concerned with any aspect of sport.
EDUCATE	Program intended primarily to educate.
DRAMA	All radio plays and serials.
CULTURE	Programs concerned with any aspect of national or regional culture, including religious affairs, philosophy, social science, language, theater, etc.
SCIENCE	Programs about the natural sciences and technology.
VARIED	Used for mainly speech-based programs, usually of a light-entertainment nature not covered by above categories. Examples are: quizzes, panel games, personality interviews, comedy and satire.
POP M	Commercial music which would generally be considered to be of current popular appeal, often featuring in current or recent record sales charts.
ROCK M	Contemporary modern music, usually written and performed by young musicians.
M.O.R. M	(Middle of the Road Music). Common term to describe music considered to be "easy-listening", as opposed to Pop, Rock or Classical. Music in this category is often, but not always, vocal, and usually of short duration (<5 min.).
LIGHT M	Classical Musical for general, rather than specialist, appreciation. Examples of music in this category are instrumental music and vocal or choral works.
CLASSICS	Performances of major orchestral works, symphonies, chamber music etc., and including Grand Opera.
OTHER M	Musical styles not fitting into any of the above categories. Particularly used for specialist music, of which Jazz, Rhythm & Blues, Folk, Country, and Reggae are examples.

After "OTHER M" is displayed, the display returns to "NEWS".

■ Enjoying Sound with DOLBY PRO LOGIC

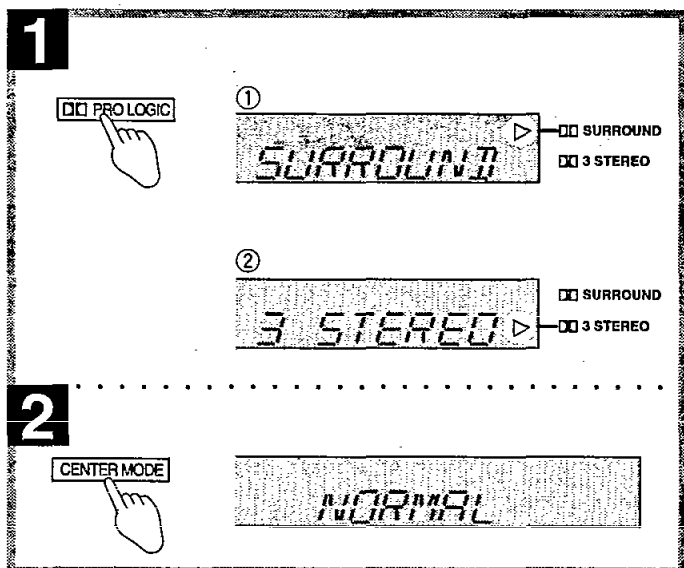
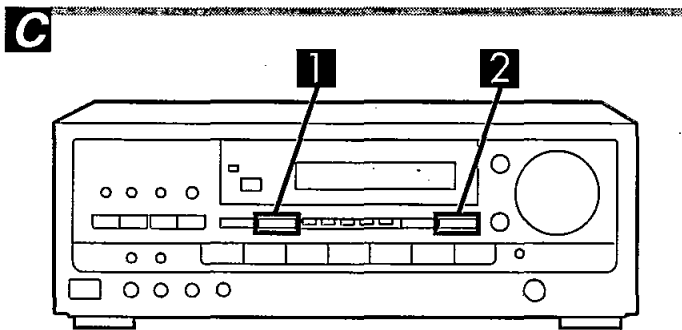
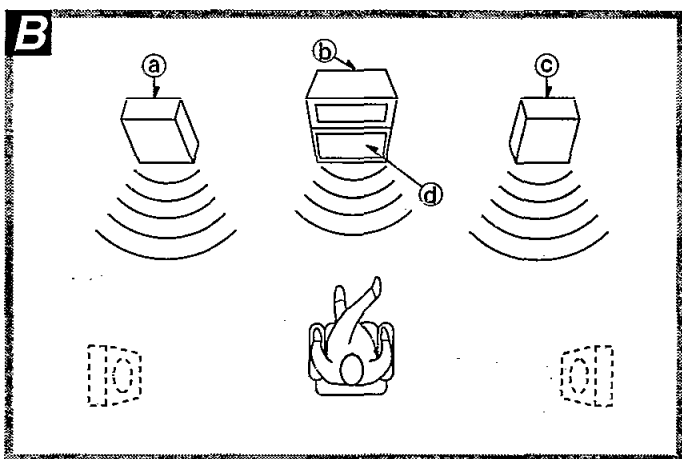
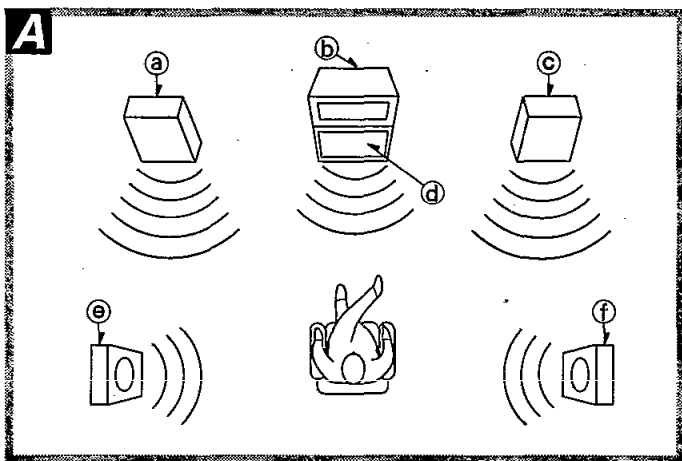

Dolby Pro Logic lets you enjoy movie software (video tapes and laser discs) in your own home with the same powerful stereophonic effect found in movie theaters. This unit has two Dolby Pro Logic modes: SURROUND and 3 STEREO.

SURROUND **A**

By reproducing the feeling of depth and movement of sound, video software or compact discs recorded with Dolby Surround provide the listener with a feeling of presence like that of a movie theater.

- Ⓐ Front speaker (Left)
- Ⓑ TV
- Ⓒ Front speaker (Right)
- Ⓓ Center speaker
- Ⓔ Surround speaker (Left)
- Ⓕ Surround speaker (Right)

3 STEREO **B**

You can enjoy audio/video sources with clear sound, more presence and a good feeling of orientation. 3 STEREO can be used with stereo sources not encoded with DOLBY SURROUND.

- Ⓐ Front speaker (Left)
- Ⓑ TV
- Ⓒ Front speaker (Right)
- Ⓓ Center speaker

Setting the center mode and adjusting speakers output level **C**

Note

- When ready to adjust speakers output level, situate yourself away from the speakers as you normally do when listening.
- First turn ON the speakers with the SPEAKERS A or B button on the receiver.
- If front speakers volume is unbalanced, adjust the balance with the BALANCE knob.
- You cannot adjust the output level of subwoofer with this receiver.

1

Press **PRO LOGIC** to turn on the Dolby Pro Logic system and select the desired mode.

When the button is pressed, the Dolby Pro Logic mode is displayed for approximately 1 second only.

- ① SURROUND mode
- ② 3 STEREO mode

Pressing it again changes the Dolby Pro Logic mode.

2

Press **CENTER MODE** to select the correct center mode.

When the button is pressed, the current center mode is displayed.

Pressing it again changes the center mode.

NORMAL

When the center speaker is smaller than the front speakers.

WIDEBAND

When the center speaker is the same size or larger than the front speakers.

PHANTOM **SURROUND only**

When no center speaker is connected.

Note

In the PHANTOM mode, the sound which would have been sent to the center speaker will be divided equally between both the left and right front speakers.

(Continued on next page)

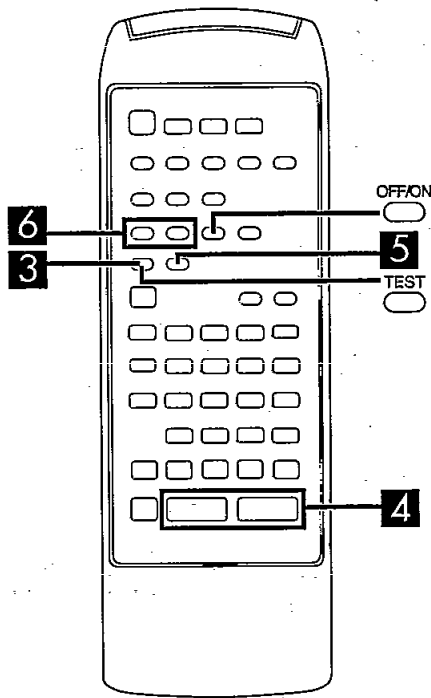

3 by remote control only

Press TEST to output a test signal.

The speaker outputting the test signal is displayed while the test is running.

- L : Front speaker (Left)
- C : Center speaker
- R : Front speaker (Right)
- S : Surround speakers

For SURROUND mode

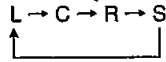

In the PHANTOM mode, the center speaker is OFF, so the test signal is not output and "C" is not displayed.

For 3 STEREO mode

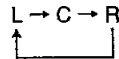

4 by remote control

Press VOLUME (-) or (+) to set the volume level normally used for enjoying the source.

The following steps are for setting the output level of the front speakers and the center/surround speakers to the same listening level.

5 by remote control only

Press CH SELECT to select the center or surround speakers.

6 by remote control only

Press CH LEVEL (-) or (+) to adjust the output level.

Adjust the output level of each speaker from the listening position until they are all identical.

-: Decrease the output level.

+: Increase the output level.

Output level can be varied within a range of -12 dB to +12 dB with front speaker output level serving as the zero point.

Note

1. The test signal is output only by the speaker you are now adjusting and does not repeat the sequence until adjustments are complete.

2. Remember you cannot adjust output level of the surround speakers if you selected the 3 stereo mode in step 1.

To stop the test signal

Press TEST.

To turn off the Dolby Pro Logic systems

Press OFF/ON.

Press once again to turn it on.

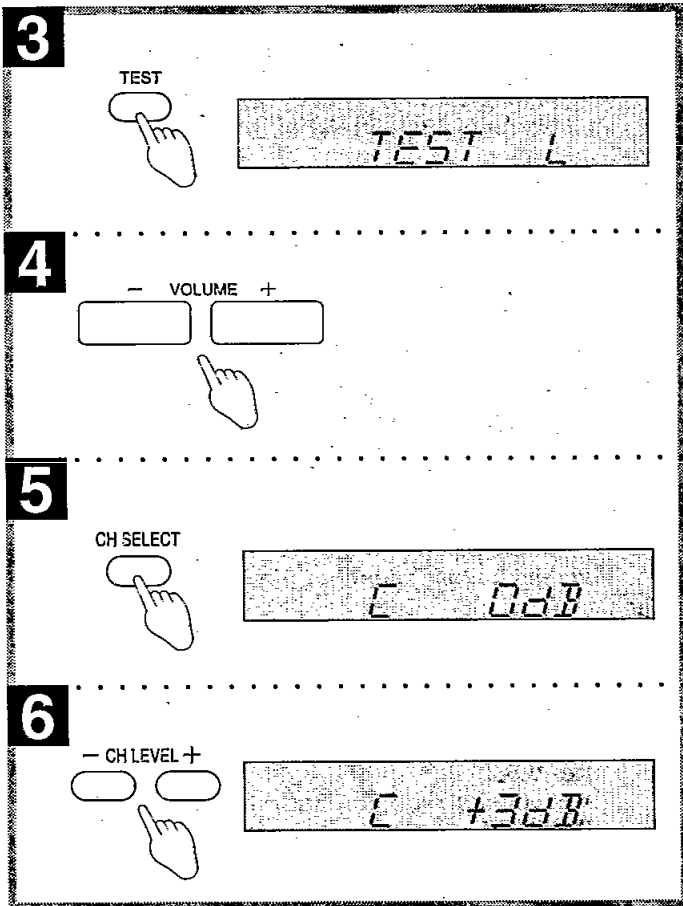

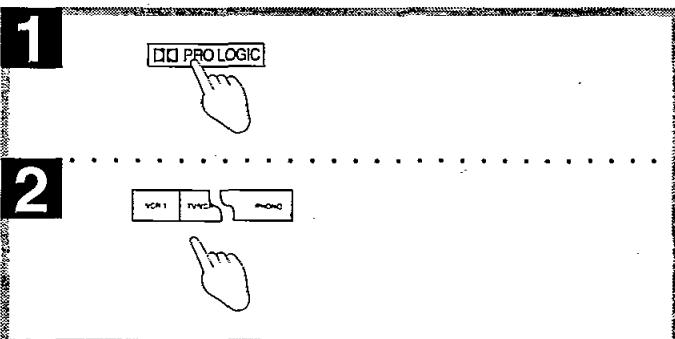
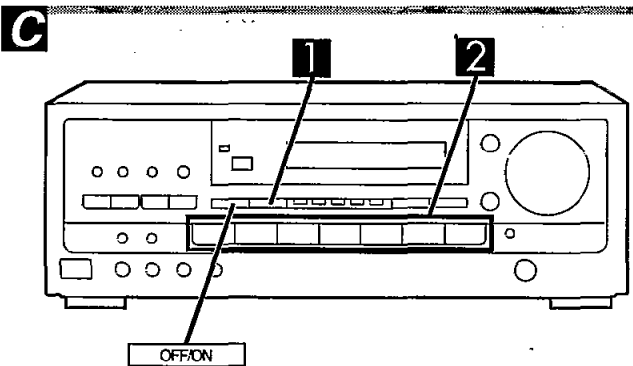
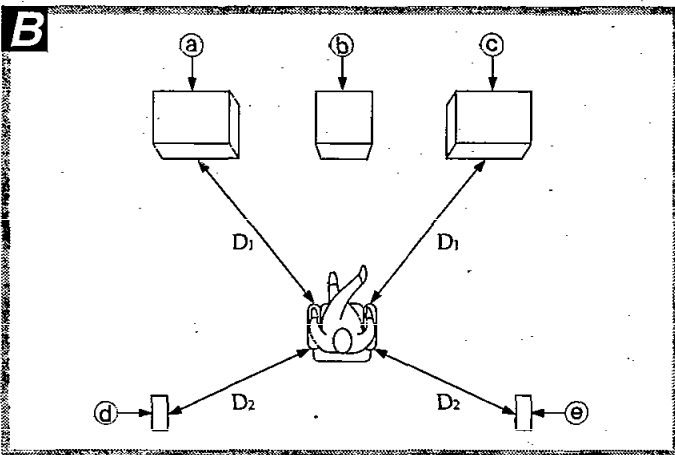
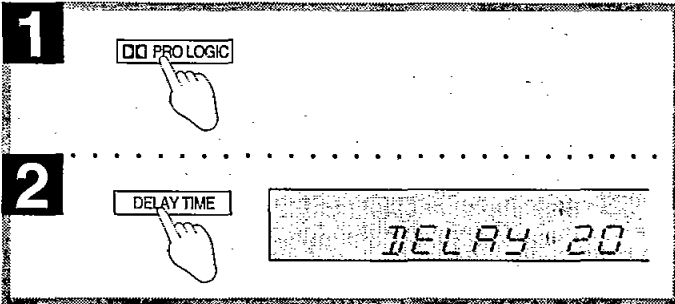
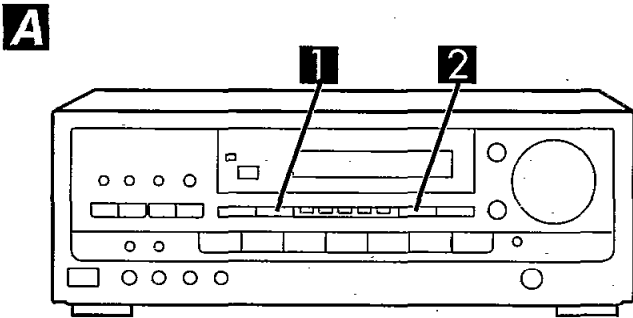

Adjusting the delay time A

When enjoying with SURROUND only

Adjust the sound from the surround speakers until the proper effect is produced.

1 Press **PRO LOGIC** to turn on the Dolby Pro Logic system and select the SURROUND mode.

2 Press **DELAY TIME** to set to the suitable time. When the button is pressed, the current delay time is displayed. Pressing it again changes the delay time.

Each time the button is pressed, the delay time will increase by 5 ms within a range of 15 ms to 30 ms.

The standard setting is 20 ms.

To calculate the delay time B

- Ⓐ Front speaker (Left)
- Ⓑ Center speaker
- Ⓒ Front speaker (Right)
- Ⓓ Surround speaker (Left)
- Ⓔ Surround speaker (Right)

D₁: Distance from front speakers
D₂: Distance from surround speakers

• If D₁ is equal to or less than D₂

Set to 15ms.

• If D₂ is less than D₁

Start at 15ms and increase by 5 ms for every 1.5 m of difference between D₁ and D₂.

Enjoying with SURROUND or 3 STEREO C

1 Press **PRO LOGIC** to turn on the Dolby Pro Logic system and select the desired mode. When the button is pressed, the Dolby Pro Logic mode is displayed. Pressing it again changes the Dolby Pro Logic mode.

2 Select the desired source and start the desired source.

Note

When employing SURROUND, use software recorded in Dolby Surround.

To turn off the Dolby Pro Logic systems

Press OFF/ON.

Manufactured under license from Dolby Laboratories Licensing Corporation.

DOLBY, the double-D symbol **DD** and "PRO LOGIC" are trademarks of Dolby Laboratories Licensing Corporation.

■ Enjoying Sound with 6 Channel Discrete

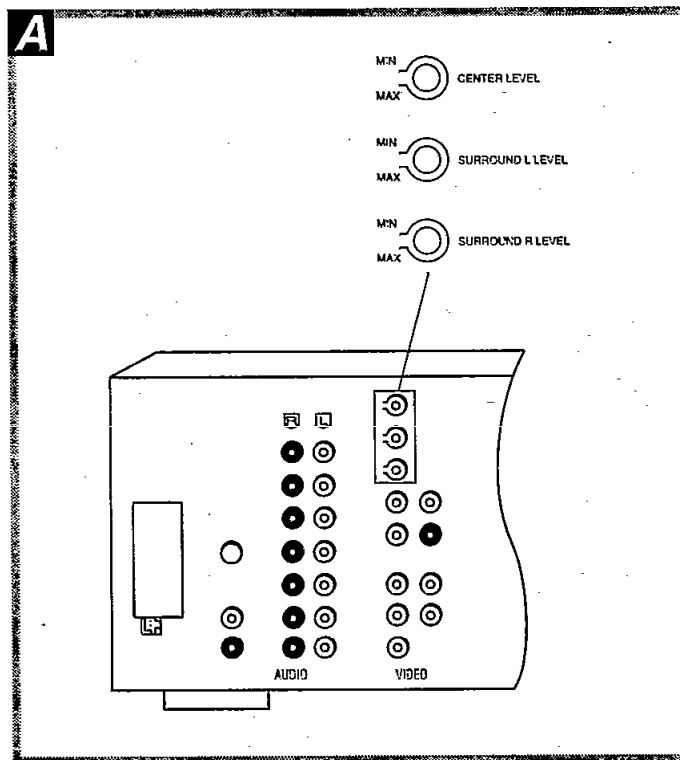
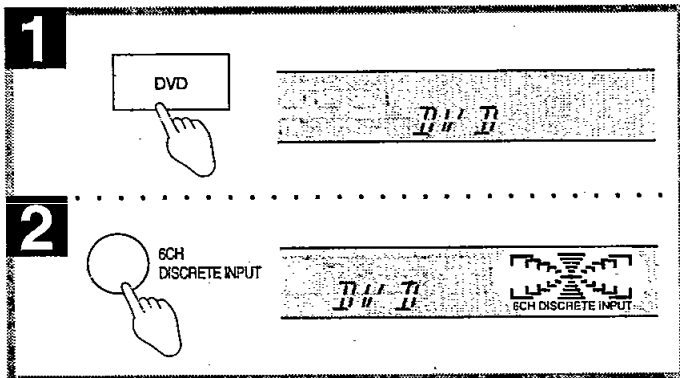
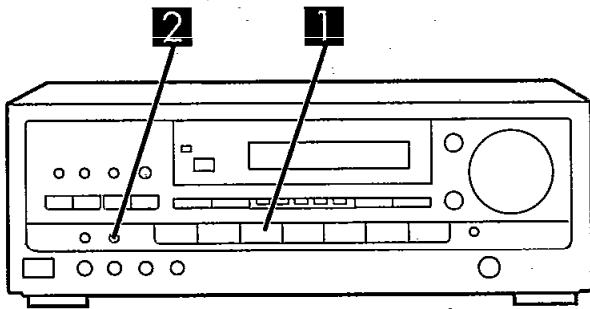

This receiver can play back 6 channel discrete sound. It has jacks for connecting to components with 6 channel discrete output, such as DVD player.

6 channel discrete output makes playback sound more real by adding depth, movement, position and other characteristics to the field of sound.

It will make you feel as if you were at the movie theater when in your own home.

To enjoy 6 channel discrete output sound

Of course, you have to connect a DVD player or other component that has 6 channel discrete output capabilities.

1 Press DVD.

2 Press 6CH DISCRETE INPUT.

If you press this button while another source (CD, PHONO, etc.) is selected, the receiver switches the source to DVD and engages the 6CH DISCRETE INPUT mode.

3 Start the desired source.

Follow your equipment's operating instructions.

Note

You cannot select Dolby Pro Logic mode while in the 6CH DISCRETE INPUT mode. If you try, the message "NOT POSSIBLE IN 6CH DISCRETE INPUT" will appear on the display.

To adjust the input level (CENTER LEVEL/SURROUND L LEVEL/SURROUND R LEVEL) **A**

When connected to a DVD player or other component with 6 channel discrete output, you can adjust input level for the center and surround (L) and (R) channels from these controls on the rear panel.



Turn CENTER LEVEL to adjust the input level of the center channel.



Turn SURROUND L LEVEL to adjust the input level of the surround (L) channel.



Turn SURROUND R LEVEL to adjust the input level of the surround (R) channel.

■ Operation Checks and Main Component Replacement Procedures

NOTE

1. This section describes procedures for checking the operation of the major printed circuit boards and replacing the main components.
2. For reassembly after operation checks or replacement, reverse the respective procedures. Special reassembly procedures are described only when required.
3. Select items from the following index when checks or replacement are required:
4. Refer the parts No. on the page of "Main Component Replacement Procedures", if necessary.

● Contents

• Checking Procedures for each P.C.B.	Page.
1. Checking for the tuner P.C.B. and FL P.C.B.	19,20.
2. Checking for the IN/OUT terminal P.C.B. and surround P.C.B.	20,21.
3. Checking for the main P.C.B.	21.
• Main Component Replacement Procedures	
1. Replacement for the power IC and regulator transistor.	22,23.

■ Checking Procedure for each P.C.B.

1. Checking for the tuner P.C.B. and FL P.C.B.

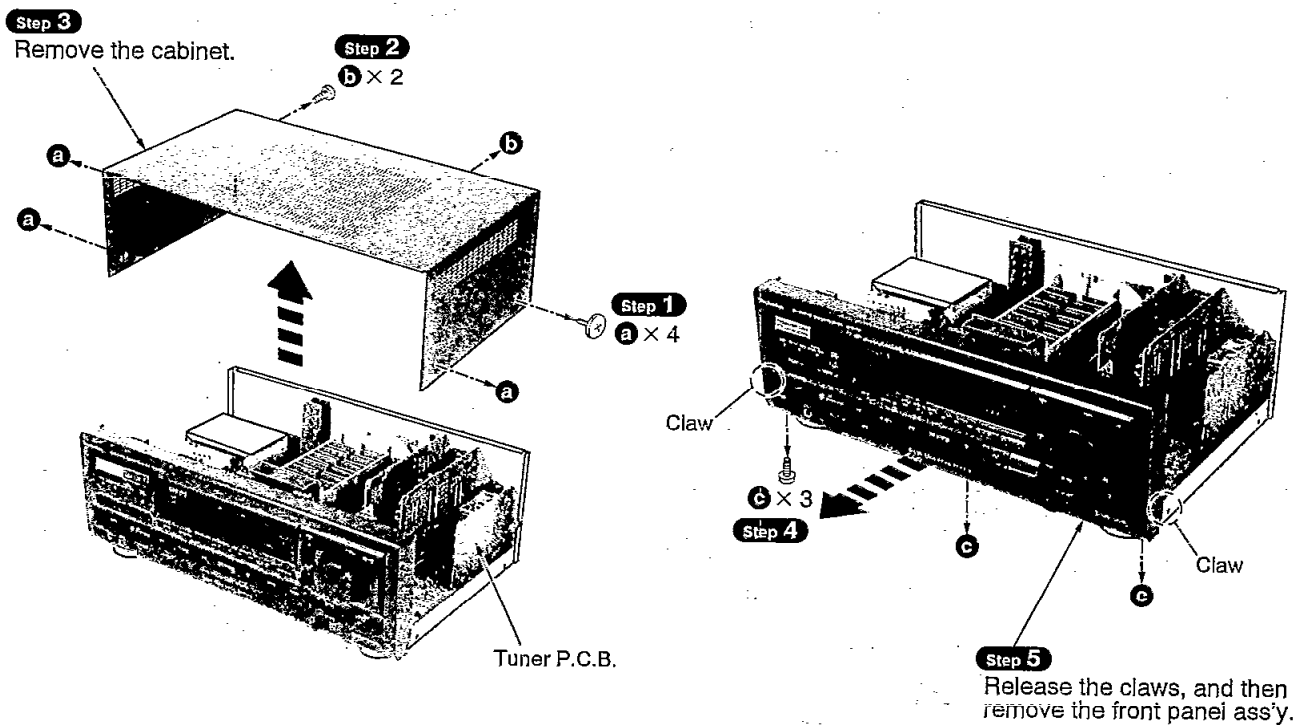

• Check the tuner P.C.B. as shown above.

Step 7
Remove the fan ass'y.

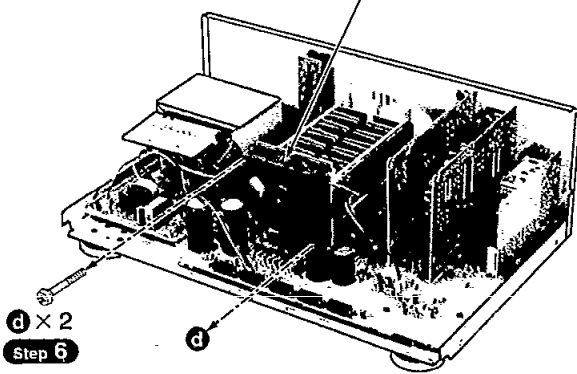

To remove each P.C.B.

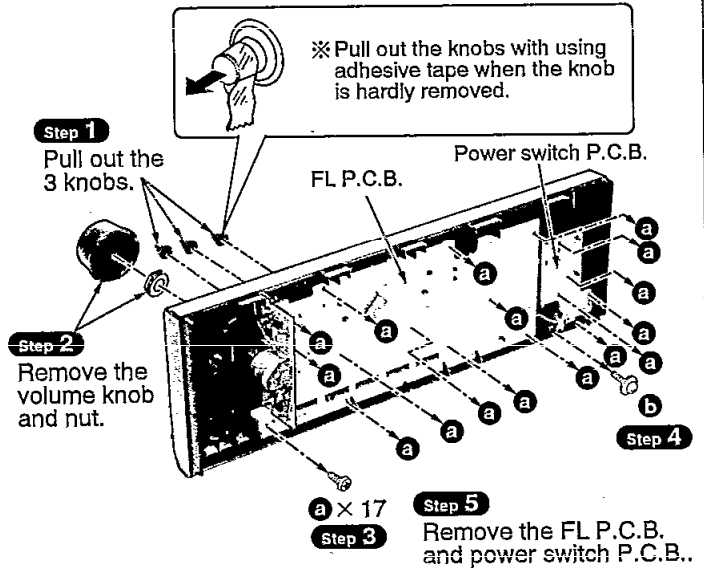

• Check the FL P.C.B. as shown below.

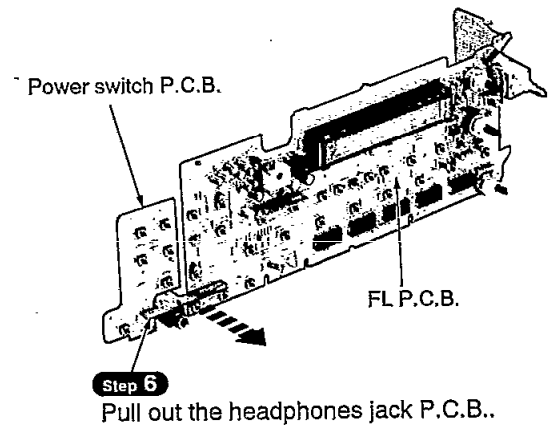
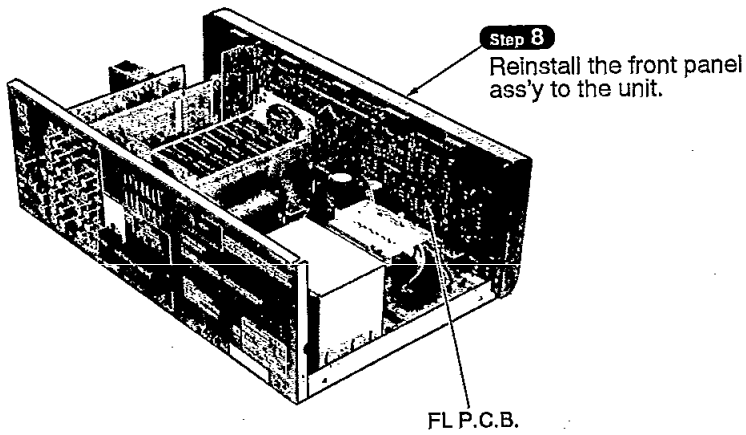

2. Checking for the IN/OUT terminal P.C.B. and surround P.C.B.

• Follow the **Step 1** ~ **Step 3** of the item 1 in checking procedure for each P.C.B. on page 19.

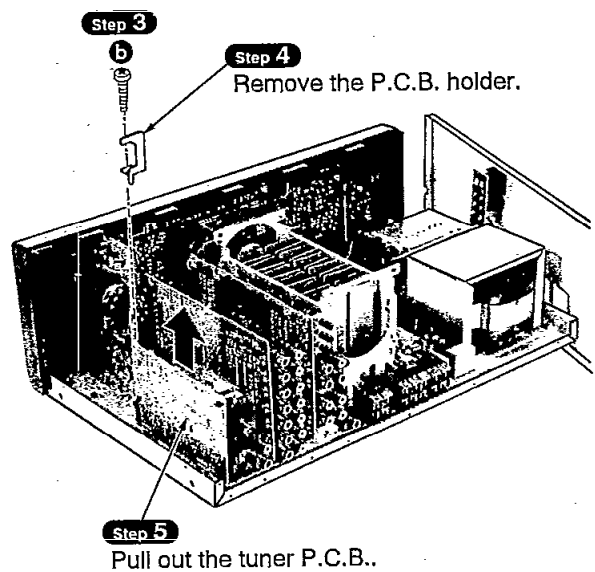
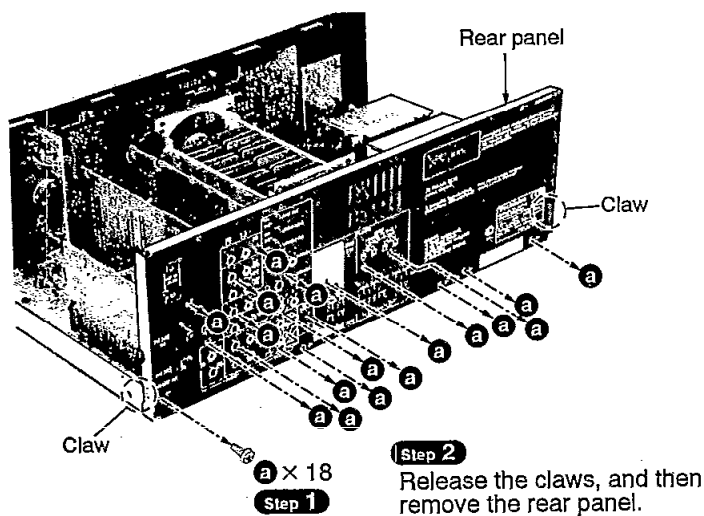

• Check the IN/OUT terminal P.C.B. as shown below.

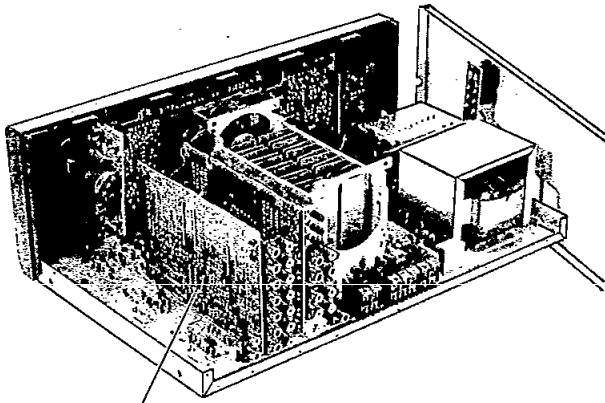

IN/OUT terminal P.C.B.

• Check the surround P.C.B. as shown below.

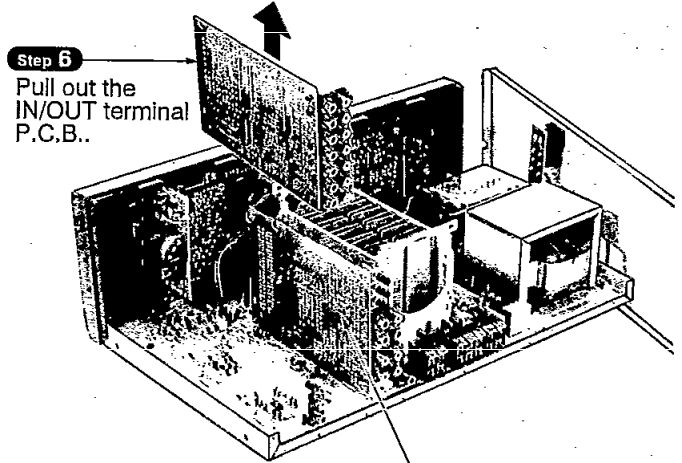

Step 6
Pull out the IN/OUT terminal P.C.B..

Surround P.C.B.

3. Checking for the main P.C.B.

• Follow the **Step 1** ~ **Step 5** of the item 1 in checking procedure for each P.C.B. on page 19.

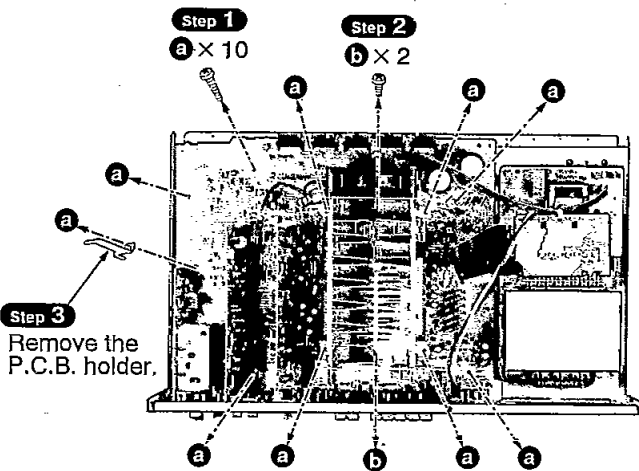

Step 5
Lift up the main P.C.B. and rear panel.

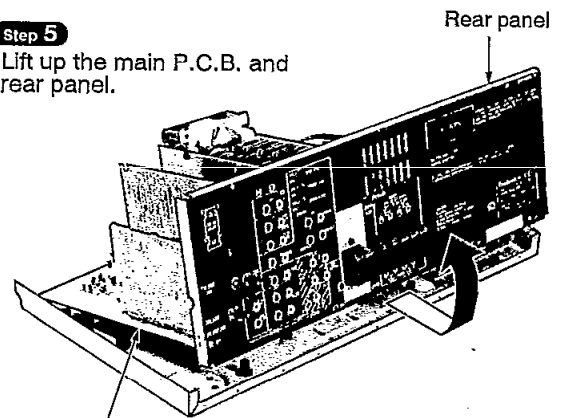

• Check the main P.C.B. as shown below.

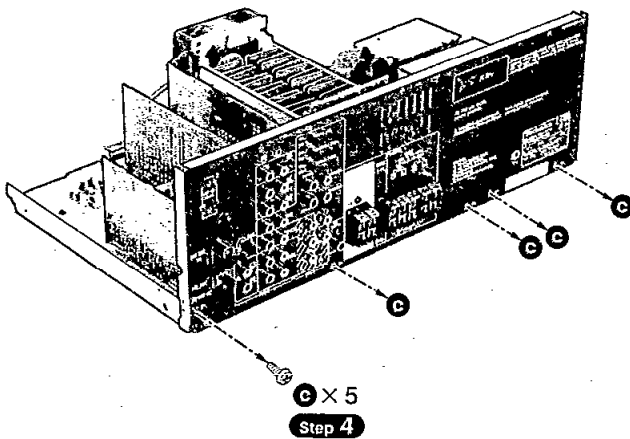

Step 6
Connect the front panel ass'y of the P.C.B. connectors to the main P.C.B. and set it as the illustration right.

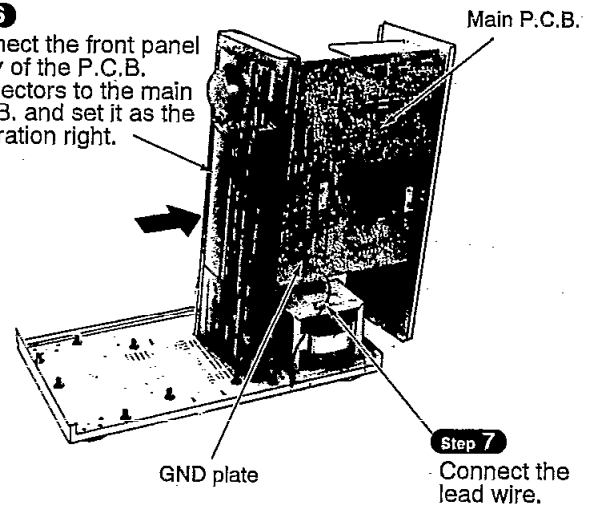

■ Main Component Replacement Procedures

1. Replacement for the power IC and regulator transistor

- Follow the **Step 1** ~ **Step 3** of the item 1 in checking procedure for each P.C.B. on page 19.

Step 1 Cut the joints as shown below. (8 points)

Locate the nipper to the thin portion of the joint.

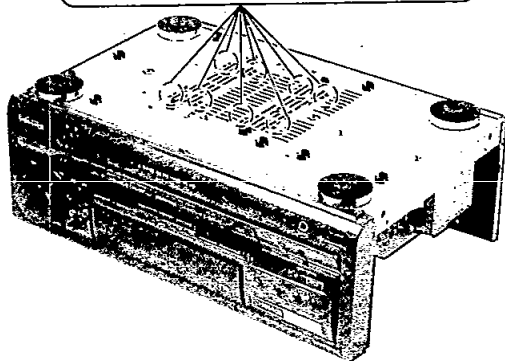
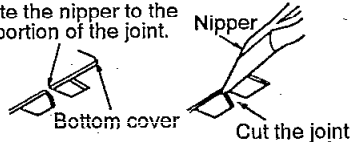

Step 2 Fold the joints. (8 points)

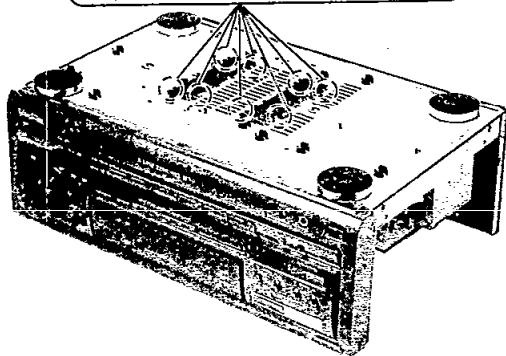
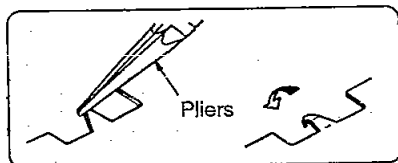

Step 3

Unsolder the terminals of power IC and regulator transistor.

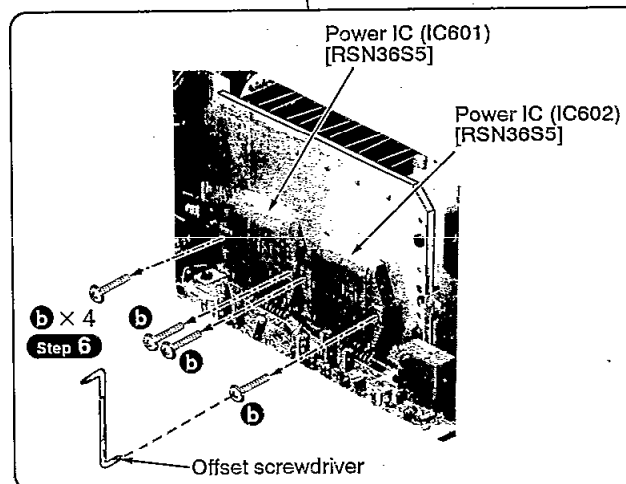
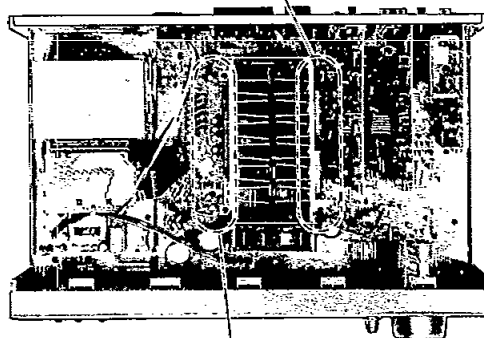
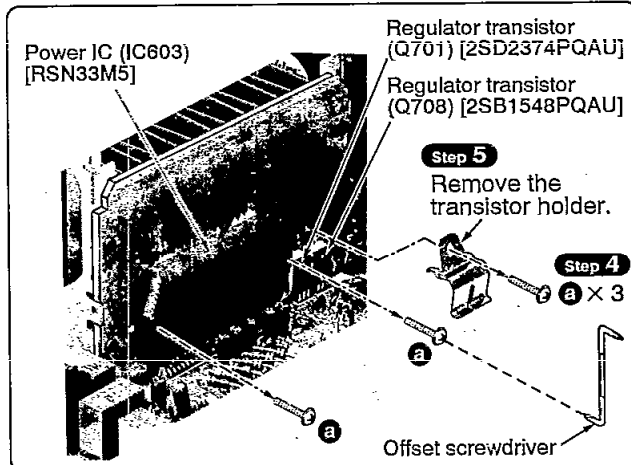
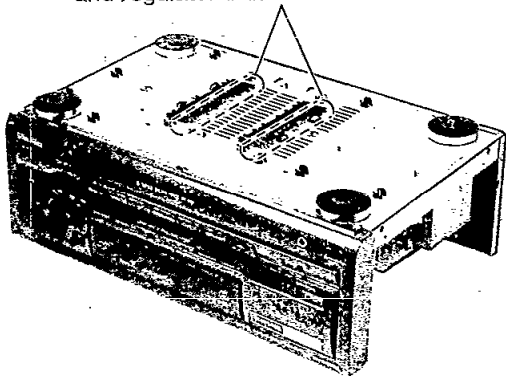

CAUTION

- After replacing the power IC or regulator transistor, apply a sufficient quantity of compound grease (RFKX0002) between the heat sink and the power IC or regulator transistor (Radiation of power IC).
- Tighten enough the screws (a, b) after replacing the power IC and regulator transistor. Otherwise, the heat radiation works little.
- When installing or removing the power IC or transistor holder, be sure to use an offset screwdriver.

—OFFSET SCREWDRIVER—

- The PROTO offset screwdriver No.34- ¼ is recommended for use in the application above.

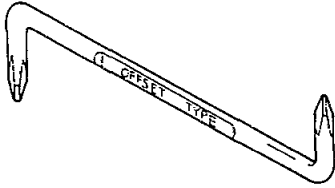

No.		
34¼	1 & 2	4¾"

- The address of PROTO International Sales is as follows.

**International Sales**

International Sales Office
Stanley-Proto Industrial Tools
14117 Industrial Park Blvd.
Covington, GA 30209 U.S.A.
Fax: 706-786-4387
Phone: 706-787-3800

Australia, New Zealand &
South Pacific
Stanley-Proto Industrial Tools
P.O.Box 10
400 Whitehorse Road
Nunawading 3131
Victoria, Australia
Fax: 61-3-894-1173
Phone: 61-3-878-9244

Japan
Stanley Works Japan
2-7-16 Hyakunin-Cho
Shinjuku-ku
Tokyo 160 Japan
Fax: 81-3-3360-8456
Phone: 81-3-3360-8458

Mexico
Herramientas Stanley S.A.
DE C.V.
Apartado Postal 675
72030 Puebla, Pue, Mexico
Fax: 52-22-494-4880
Phone: 52-22-495-300

South & Central America,
Puerto Rico, The Caribbean
Stanley Inter-America
2101 N.W. 84th Ave.
Miami, Florida 33122
Fax: 305-594-4261
Phone: 305-591-3828

Singapore, Indonesia,
Philippines, Korea, Hong
Kong, Malaysia, China.
Stanley-Proto Asia Pacific
12 Gul Drive
Singapore 2262
Fax: 65-861-3206
Phone: 65-862-0883

Thailand
Stanley-Proto Thailand Ltd.
1017 Moo 13 Bangnatrad
Highway, Tambol Bankaew
Amphur Bangplee
Samutprakarn, Thailand
Fax: 66-2-316-6071
Phone: 66-2-316-8655

Europe
Stanley-Proto Europe
Woodside, Sheffield
S39PD
England
Fax: 44-742-739-038
Phone: 44-742-768-888

Canada
Stanley-Proto Canada
1100 Corporate Drive
Burlington, Ontario
Canada, L7L 5R6
Fax: 416-335-0075
Phone: 416-335-0075

Middle East, Mediterranean
& Africa
Stanley-MEMA
Cory House The Ring
Bracknell Berkshire
RG 12 1A2
England
Fax: 44-344-485-526
Phone: 44-344-51813

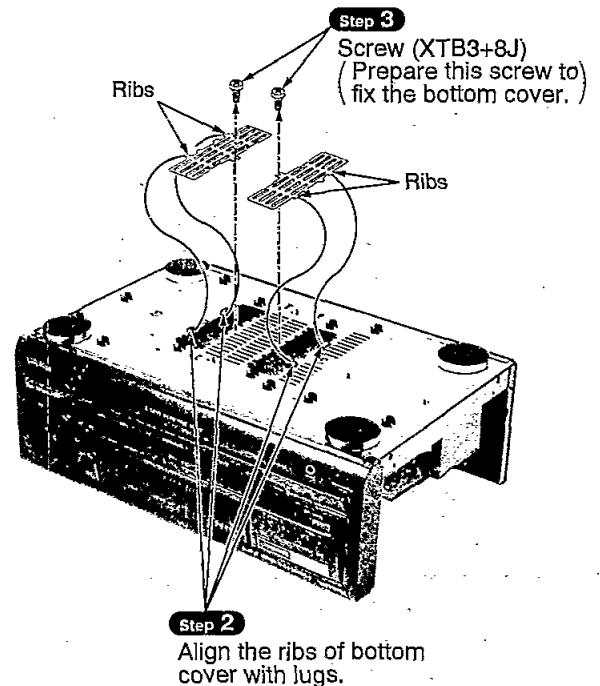
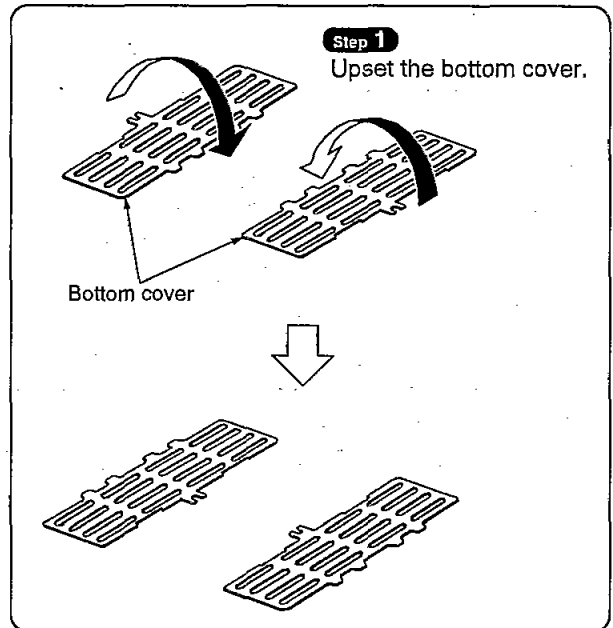
Installation of the bottom cover after replacement

Fan Motor Troubleshooting

The Model SA-AX710 employ fan motor error sensing electronics.

If the cooling fan is not operating and "OVER LOAD" is displayed on the FL display, check the fan motor and its driving circuit.

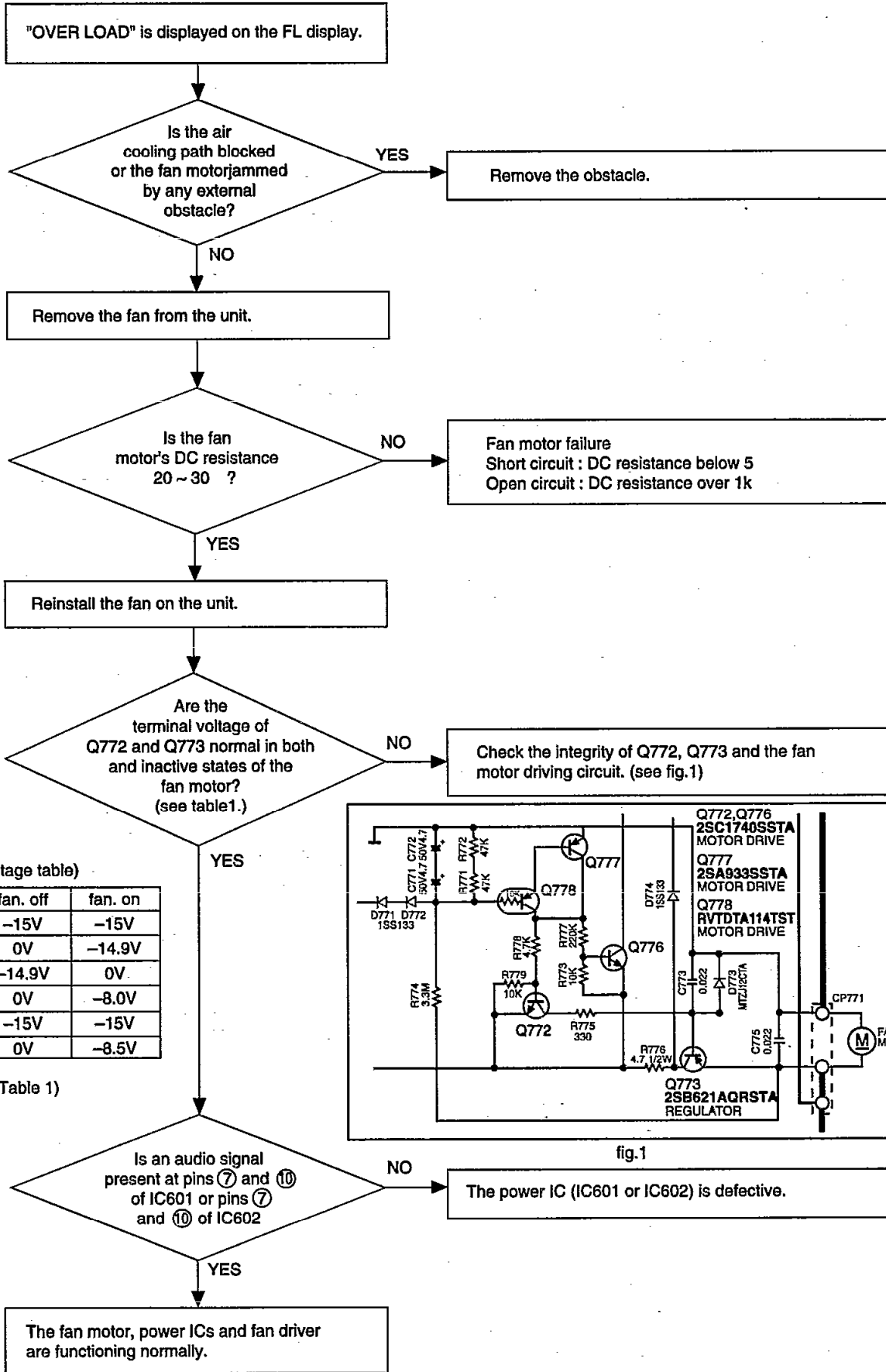

(Voltage table)

		fan. off	fan. on
Q772	E	-15V	-15V
	C	0V	-14.9V
	B	-14.9V	0V
Q773	E	0V	-8.0V
	C	-15V	-15V
	B	0V	-8.5V

(Table 1)

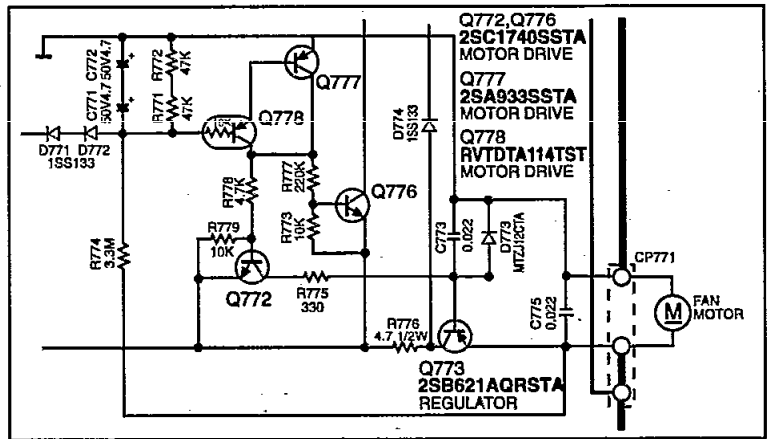

fig.1

Troubleshooting

This unit has test points on each circuit board block for use in troubleshooting.

CONNECTION

Connect either a CD player, tape deck or AF oscillator to the input terminals of the unit.

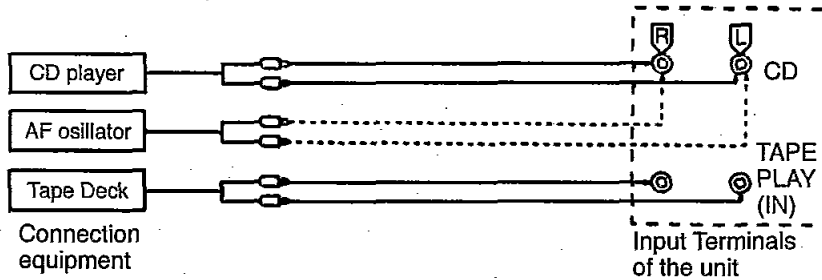

REQUIRED ITEMS

- 1. Testing with a CD player ——— Test disc (SZZP1054C / first program, 1kHz, 0dB)
- 2. Testing with a tape deck ——— Test tape (QZZCLA / 315Hz, 0dB)
- 3. Testing with a AF oscillator ——— Set the output at 500Hz, 200mV
- 4. Oscilloscope (min. 10MHz) - - - - - To measure the output waveform at the test points.



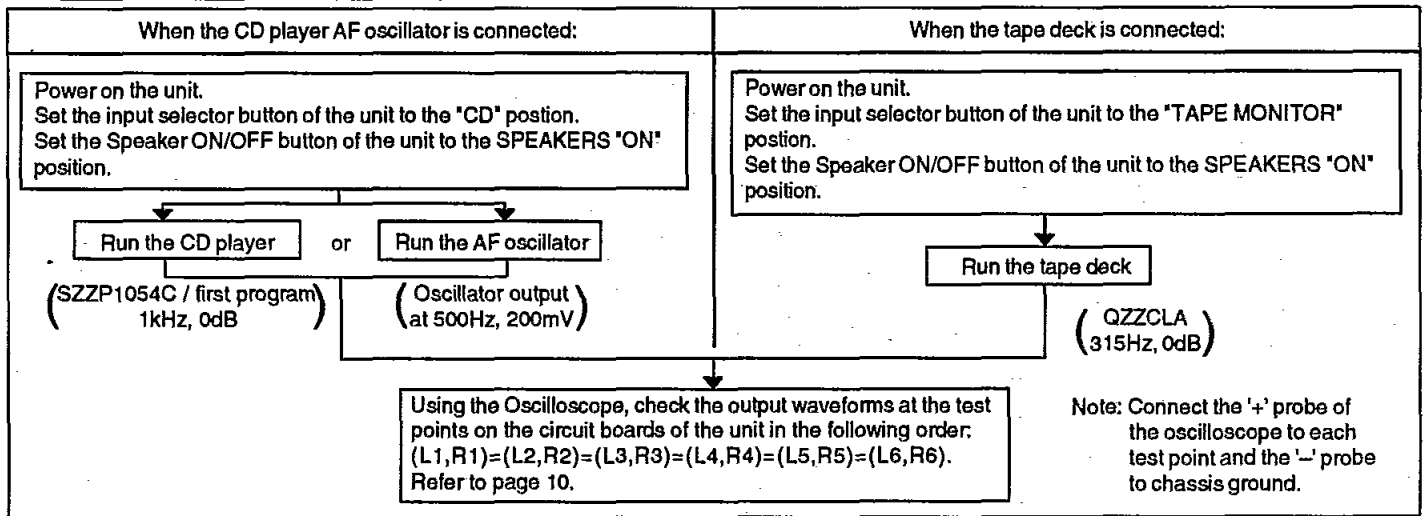



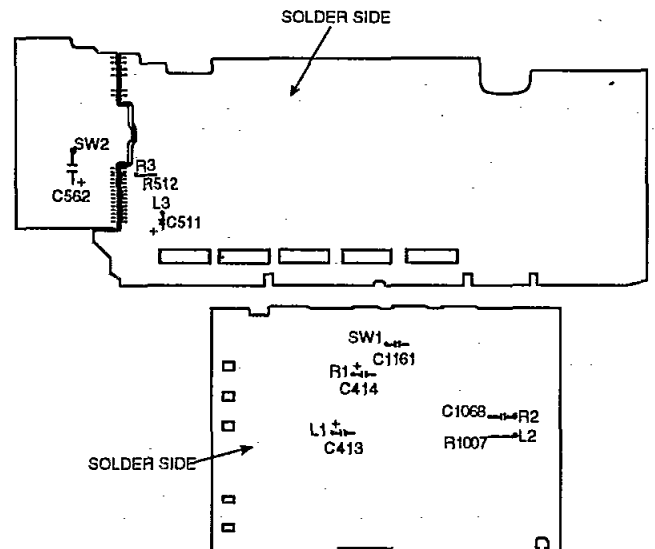
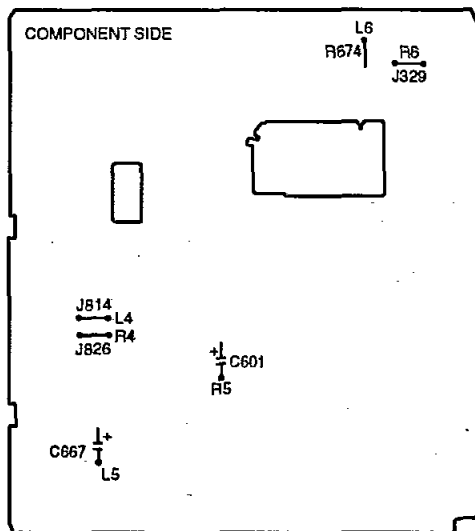

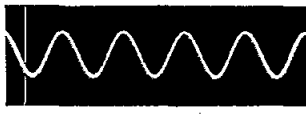
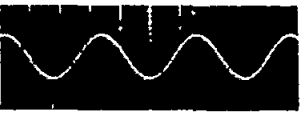
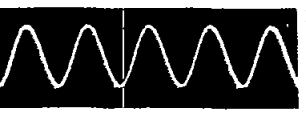

TEST PROCEDURE FOR AMPLIFIER CIRCUIT



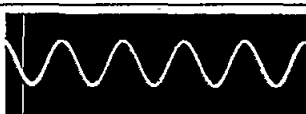
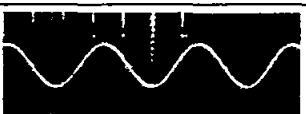
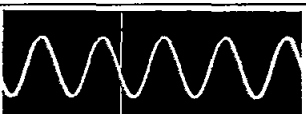
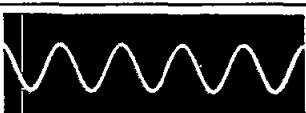
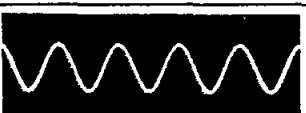
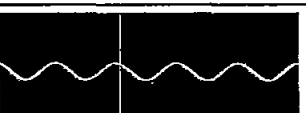
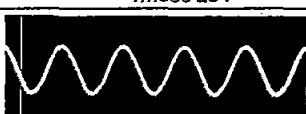
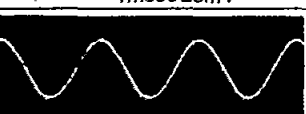
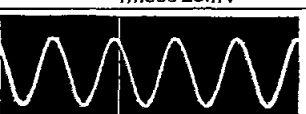

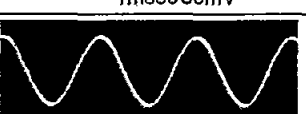
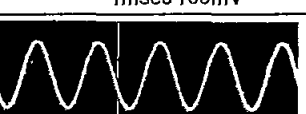
TEST POINTS POSITIONS OF AMPLIFIER CIRCUIT

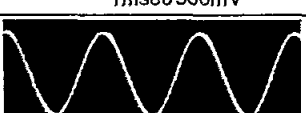
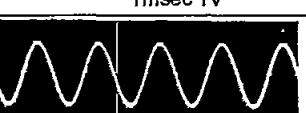

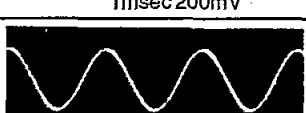
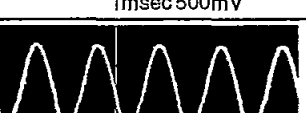

NORMAL WAVEFORMS OF AMPLIFIER CIRCUIT AND LIKELY FAULTY BLOCKS

TP	CD player	Tape deck	AF oscillator	Likely faulty block if the normal waveform shown at the left is not present.
L1/R1	 0.5msec 5V	 1msec 500mV	 1msec 500mV	Input selector block IC402 & area
SW1	 0.5msec 0.1V	 1msec 20mV	 1msec 20mV	Sub-Woofers amplifier IC1151 & area
L2/R2	 0.5msec 5V	 1msec 500mV	 1msec 500mV	Dolby pro logic block IC1001 & IC1002 & area
SW2	 1msec 25V	 1msec 25mV	 1msec 25mV	Master volume block VR501 & area
L3/R3	 0.5msec 500mV	 1msec 50mV	 1msec 100mV	Master volume block VR501 & area
L4/R4	 0.5msec 500mV*	 1msec 500mV	 1msec 1V	Tone control block IC511 & area
L5/R5	 0.5msec 200mV*	 1msec 200mV	 1msec 500mV	Power limiter block Q581 to Q584 & area
L6/R6	 0.5msec 10V*	 1msec 10V	 1msec 10V	Main amplifier block IC601, IC603 & area

Measurement conditions. Volume control (VR501), Treble control (VR512) and Bass control (VR511) positions : 
*Volume control position (VR501) for these test : 

CHECKING PROCEDURE FOR SURROUND CIRCUIT

Outputting surround signal normally requires that opposite phase signals be applied to both the left and right channels. However, this unit incorporates a service mode, allowing the surround circuit to be tested using in-phase signals.

When the CD player or AF oscillator is connected :	When the tape deck is connected :
<div style="border: 1px solid black; padding: 5px; margin-bottom: 5px;">Power on the unit. Set the input selector button of the unit to the "CD" position.</div> <div style="text-align: center;">↓</div> <div style="border: 1px solid black; padding: 5px; margin-bottom: 5px;">While pressing both VCR1 button and Speakers button, press the "Power" button.</div> <div style="text-align: center;">↓</div> <div style="border: 1px solid black; padding: 5px; margin-bottom: 5px;">The letter "SURROUND" flash on the FL display.</div> <div style="text-align: center;">↓</div> <div style="text-align: center;"></div>	<div style="border: 1px solid black; padding: 5px; margin-bottom: 5px;">Power on the unit. Set the input selector button of the unit to the "TAPE MONITOR" position.</div> <div style="text-align: center;">↓</div> <div style="border: 1px solid black; padding: 5px; margin-bottom: 5px;">While pressing both VCR1 button and Speakers button, press the "Power" button.</div> <div style="text-align: center;">↓</div> <div style="border: 1px solid black; padding: 5px; margin-bottom: 5px;">The letter "SURROUND" flash on the FL display.</div> <div style="text-align: center;">↓</div> <div style="text-align: center;"></div>

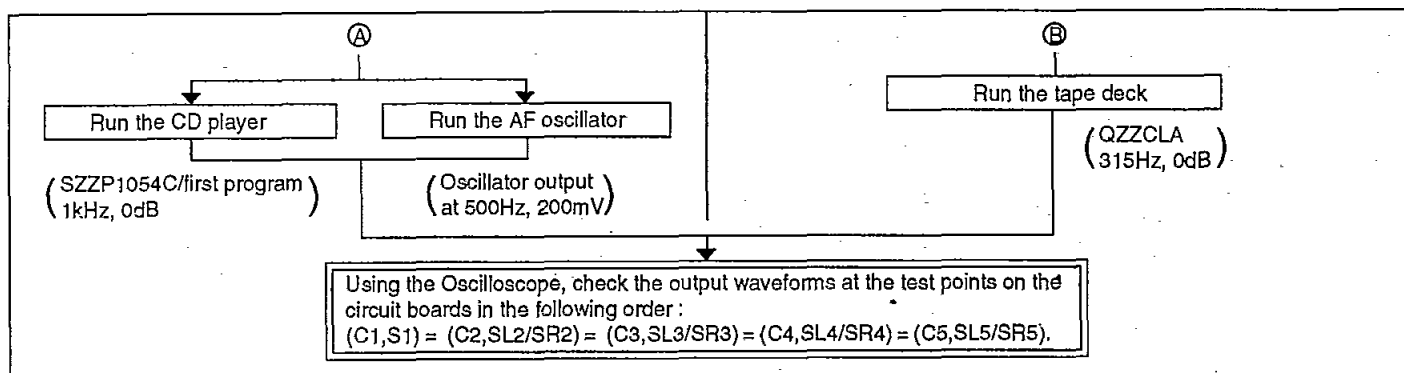

• To exit the service mode, power off the unit.

TEST POINTS POSITIONS OF SOURROUND CIRCUIT

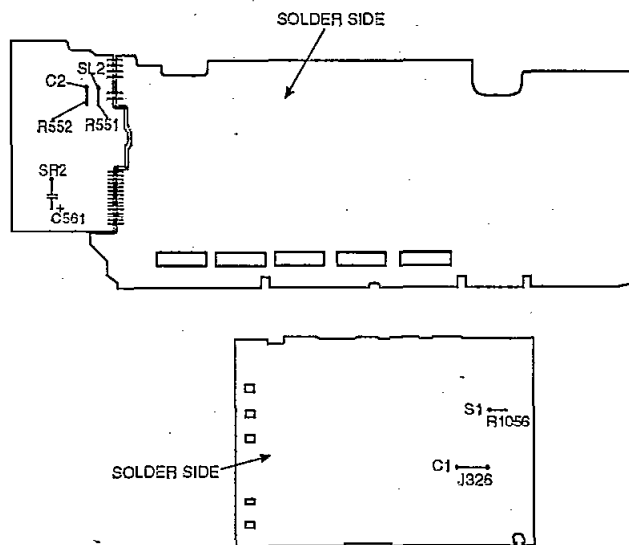
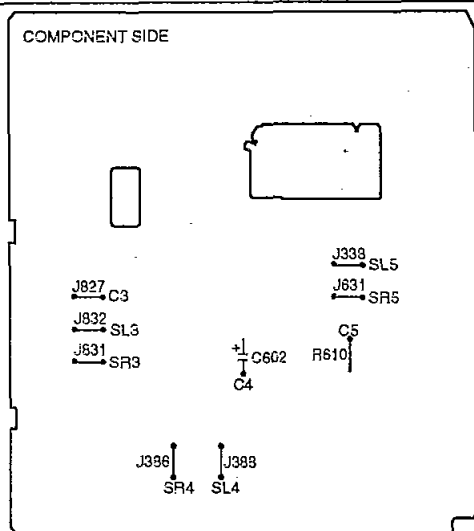



NORMAL WAVEFORMS OF AMPLIFIER CIRCUIT AND LIKELY FAULTY BLOCKS

TP	CD player	Tape deck	AF oscillator	Likely faulty block if the normal waveform shown at the left is not present.
C1 S1	 0.5msec 1V	 1msec 100mV	 1msec 200mV	Dolby pro logic block IC1002 & area
C2 SL2/SR2	 0.5msec 200mV	 1msec 20mV	 1msec 50mV	Master volume block VR501 & area
C3 SL3/SR3	 0.5msec 5V	 1msec 500mV	 1msec 1V	Tone control block IC551, IC552 & area

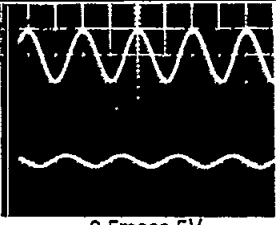
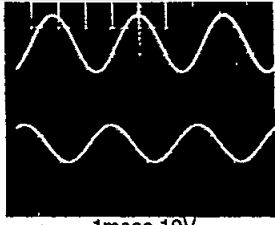
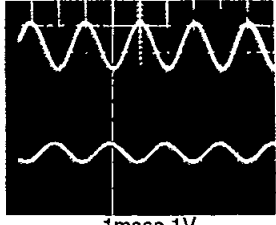
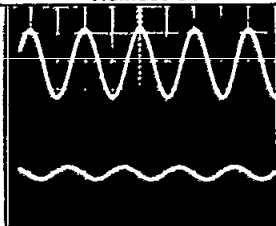
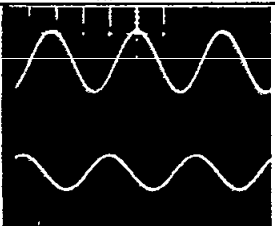
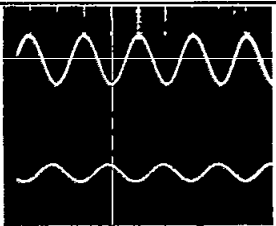
NORMAL WAVEFORMS OF AMPLIFIER CIRCUIT AND LIKELY FAULTY BLOCKS

TP	CD player	Tape deck	AF oscillator	Likely faulty block if the normal waveform shown at the left is not present.
C4 SL4/SR4				Power limiter block Q551 to Q552 & area
C5 SL5/SR5				Main amplifier block IC602 & area

Measurement conditions. Volume control (VR501), Tremble control (VR512) and Bass control (VR511) positions:  
 *Volume control position (VR501) for these test 

CIRCUIT BLOCKS

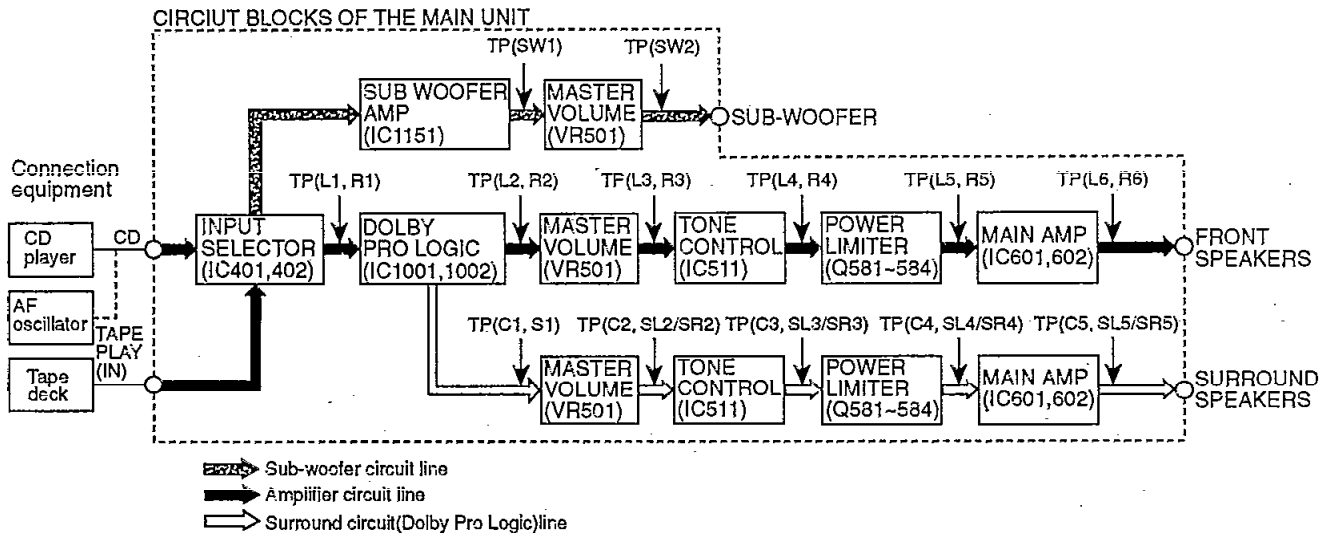

OVERLOAD DETECTION FUNCTION

The HIC protection circuit functions if any cord at a speaker terminal is short-circuited or if the unit overheats because of improper operation. At the same time, "OVERLOAD" scrolls across the FL display.
 In this state, all keys remain in operative; if any key is pressed, "SWITCH OFF POWER" scrolls across the FL display.
 If an overload occurs, immediately power off the unit and check the speaker connection, venting holes and cooling fans. After fixing any faults, power on the unit again and check for proper operation.
 If no defects are found, or if the unit remains overload after it is power on again, check the circuit for faults.

■ Schematic Diagram

	Page		Page
A TUNER CIRCUIT	30, 31	F SURROUND CIRCUIT	38, 39
B IN/OUT TERMINAL CIRCUIT	32 - 34	G MAIN CIRCUIT	38 - 42
C FL CIRCUIT	35 - 37	H TRANSFORMER CIRCUIT	42
D HEADPHONES CIRCUIT	37	I POWER SUPPLY CIRCUIT	42
E POWER SWITCH CIRCUIT	37	J AC IN CIRCUIT	42

(This schematic diagram may be modified at any time with the development of new technology.)

Notes:











- S946 : Power "STANDBY ϕ /ON" switch. (POWER, STANDBY ϕ /ON)
- S948 : Muting switch. (MUTING)
- S950 : FM mode select switch. (FM AUTO/MONO)
- S951 : Band select switch. (BAND)
- S952 : Tuning switch. (V)
- S953 : Tuning switch. (Δ)
- S954 : Sleep switch. (SLEEP)
- S955 : Memory switch. (MEMORY)
- S956 : Preset tuning switch. (V)
- S957 : Preset tuning switch. (Δ)
- S958 : Help/reset switch. (-HELP -RESET)
- S965 : 6ch discrete input select switch. (6CH DISCRETE INPUT)
- S970 : PTY search switch. (SEARCH)
- S971 : EON ON/OFF switch. (EON)
- S972 : PTY select switch. (Δ)
- S973 : PTY select switch. (V)
- S974 : RDS display mode select switch. (DISPLAY MODE)
- S975 : DVD switch. (DVD)
- S976 : Delay time adjust switch. (DELAY TIME)
- S980 : Speakers select switch. (SPEAKERS A)
- S981 : Speakers select switch. (SPEAKERS B)
- S982 : Loudness ON/OFF switch. (LOUDNESS)
- S983 : DOLBY PRO LOGIC OFF ON switch. (OFF/ON).
- S984 : DOLBY PRO LOGIC mode detect switch. (\square PRO LOGIC)
- S985 : Center mode select switch. (CENTER MODE)
- S991 : Phono switch. (PHONO)
- S992 : Tuner switch. (TUNER)
- S993 : CD switch. (CD)
- S994 : Tape monitor switch. (TAPE MONITOR)
- S995 : TV/VCR 2 switch. (TV/VCR 2)
- S996 : VCR1 switch. (VCR 1)
- VR401 : Input level control VR. (SURROUND L LEVEL)
- VR402 : Input level control VR. (SURROUND R LEVEL)
- VR403 : Input level control VR. (CENTER LEVEL)
- VR501 : Volume control VR. (VOLUME)
- VR502 : Balance control. (BALANCE)
- VR511 : Bass control VR. (BASS)
- VR512 : Treble control VR. (TREBLE)

- Indicated voltage values are the standard values for the unit measured by the DC electronic circuit tester (high-impedance) with the chassis taken as standard. Therefore, there may exist some errors in the voltage values, depending on the internal impedance of the DC circuit tester.

\square mark FM
 () AM
 < > Fan motor OFF
 [] Fan motor ON

- Important safety notice:
Components identified by \triangle mark have special characteristics important for safety.
Furthermore, special parts which have purposes of fire-retardant (resistors), high-quality sound (capacitors), low-noise (resistors), etc. are used. When replacing any of components, be sure to use only manufacturer's specified parts shown in the parts list.

- **Caution!**
IC and LSI are sensitive to static electricity.
Secondary trouble can be prevented by taking care during repair.
Cover the parts boxes made of plastics with aluminum foil.
Ground the soldering iron.
Put a conductive mat on the work table.
Do not touch the legs of IC or LSI with the fingers directly.

-  : FM SIGNAL LINE
-  : FM OSC SIGNAL LINE
-  : AM SIGNAL LINE
-  : AM OSC SIGNAL LINE
-  : MAIN SIGNAL LINE
-  : CENTER SPEAKER SIGNAL LINE
-  : SURROUND SPEAKER SIGNAL LINE
-  : SUB WOOFER SPEAKER SIGNAL LINE
-  : REC OUT SIGNAL LINE
-  : +B LINE
-  : -B LINE

A TUNER CIRCUIT (P.C.Board: on page 43)

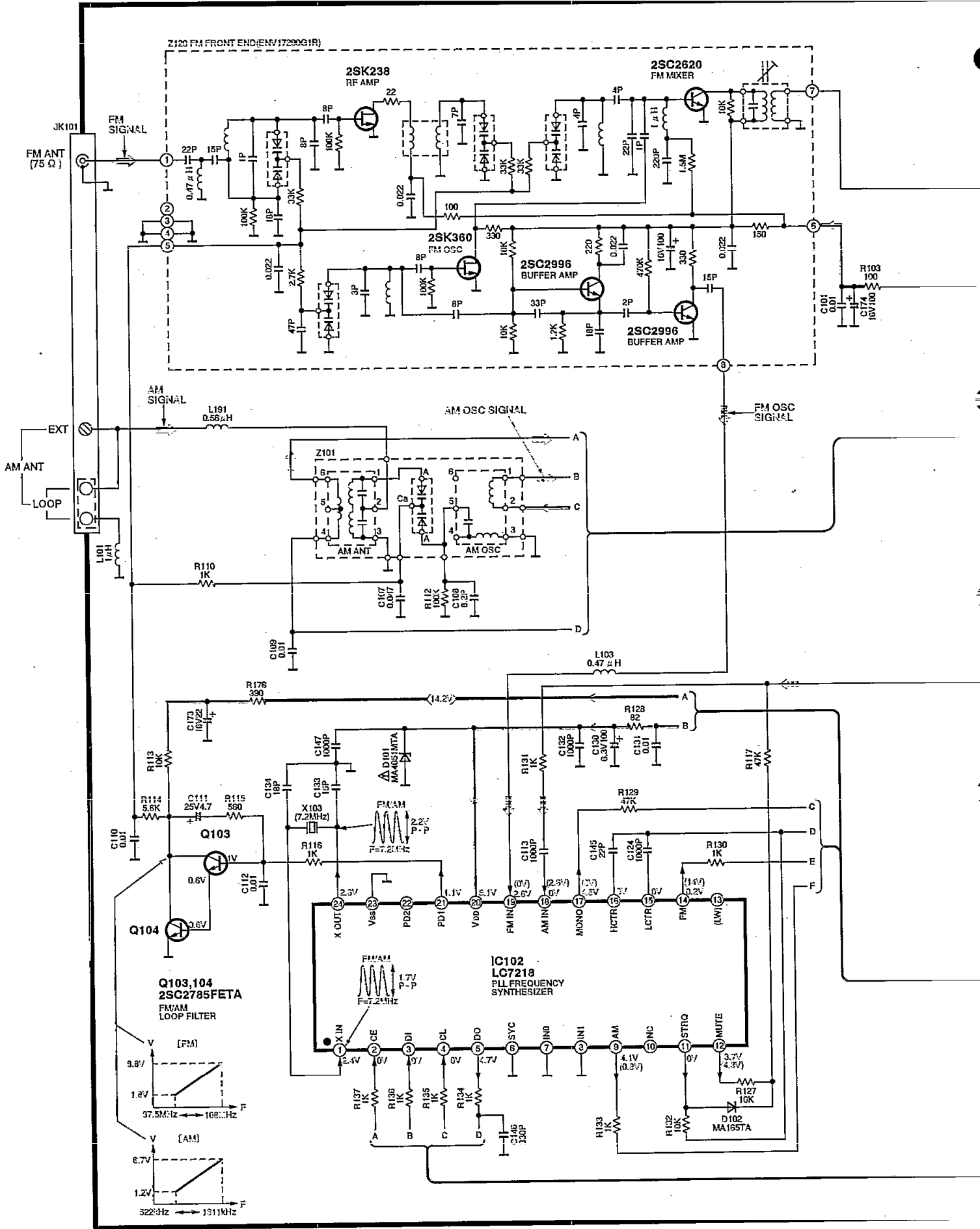

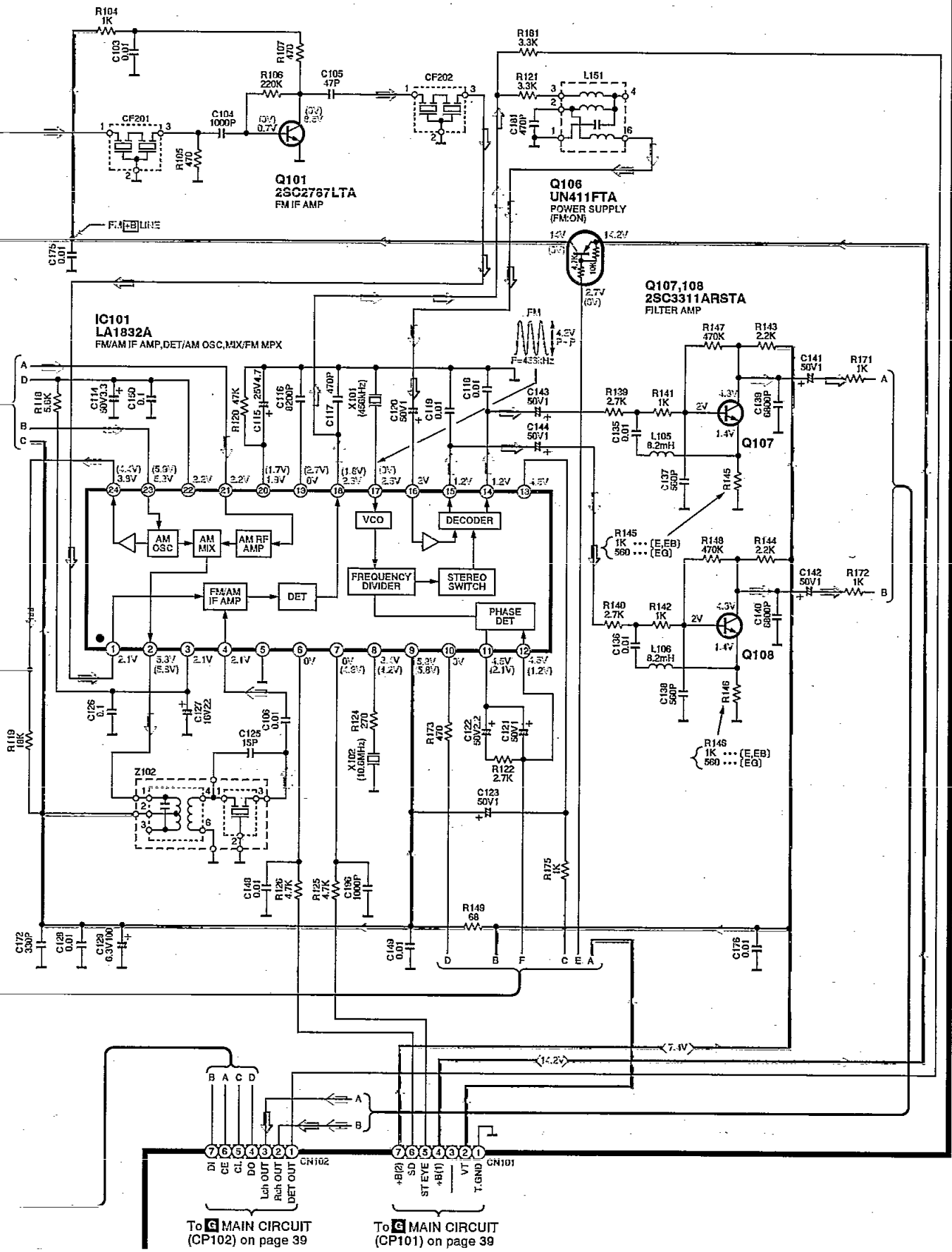

To MAIN CIRCUIT (CP102) on page 39

To MAIN CIRCUIT (CP101) on page 39

B IN/OUT TERMINAL CIRCUIT (P.C.Board: on page 44)

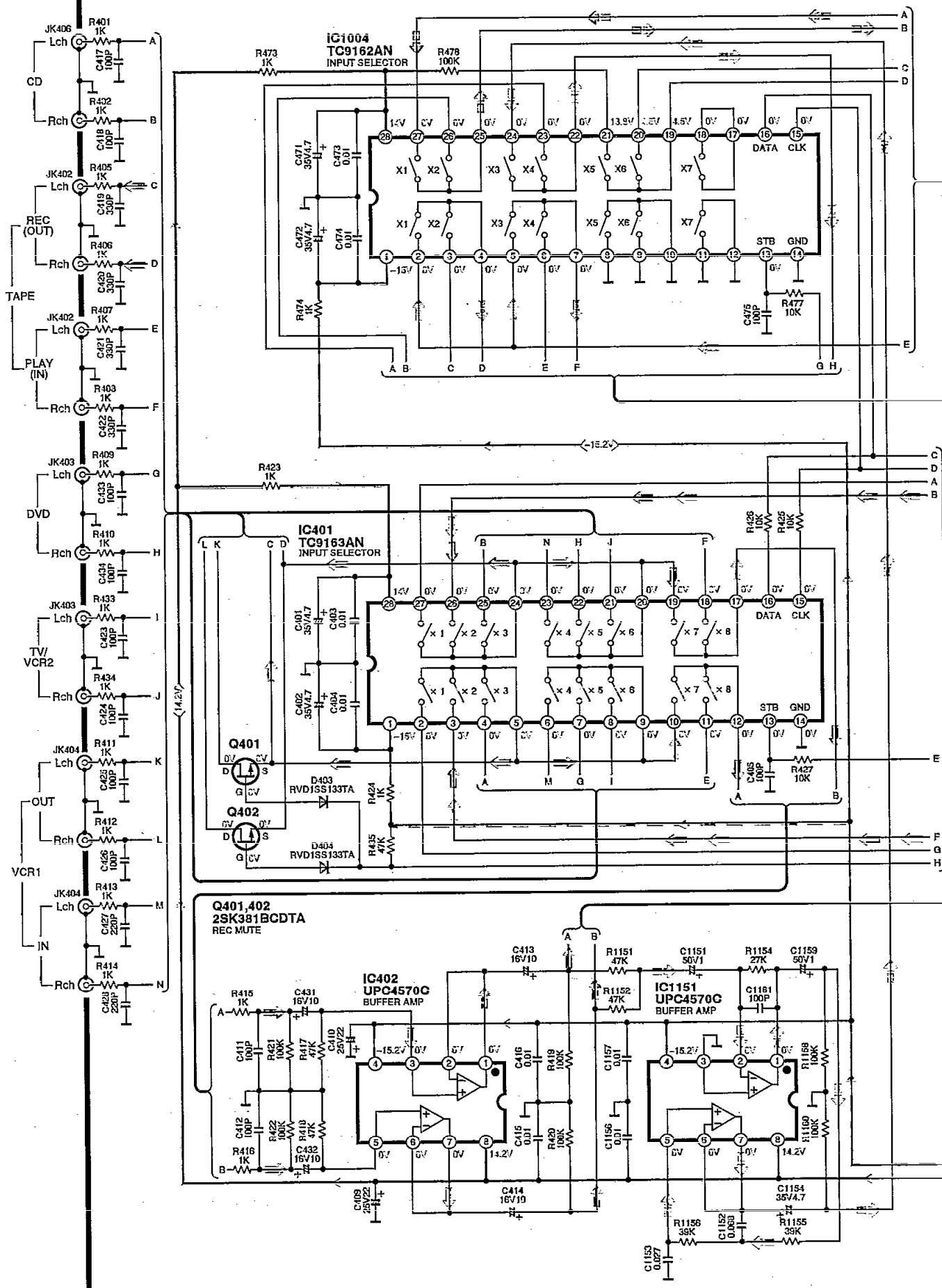

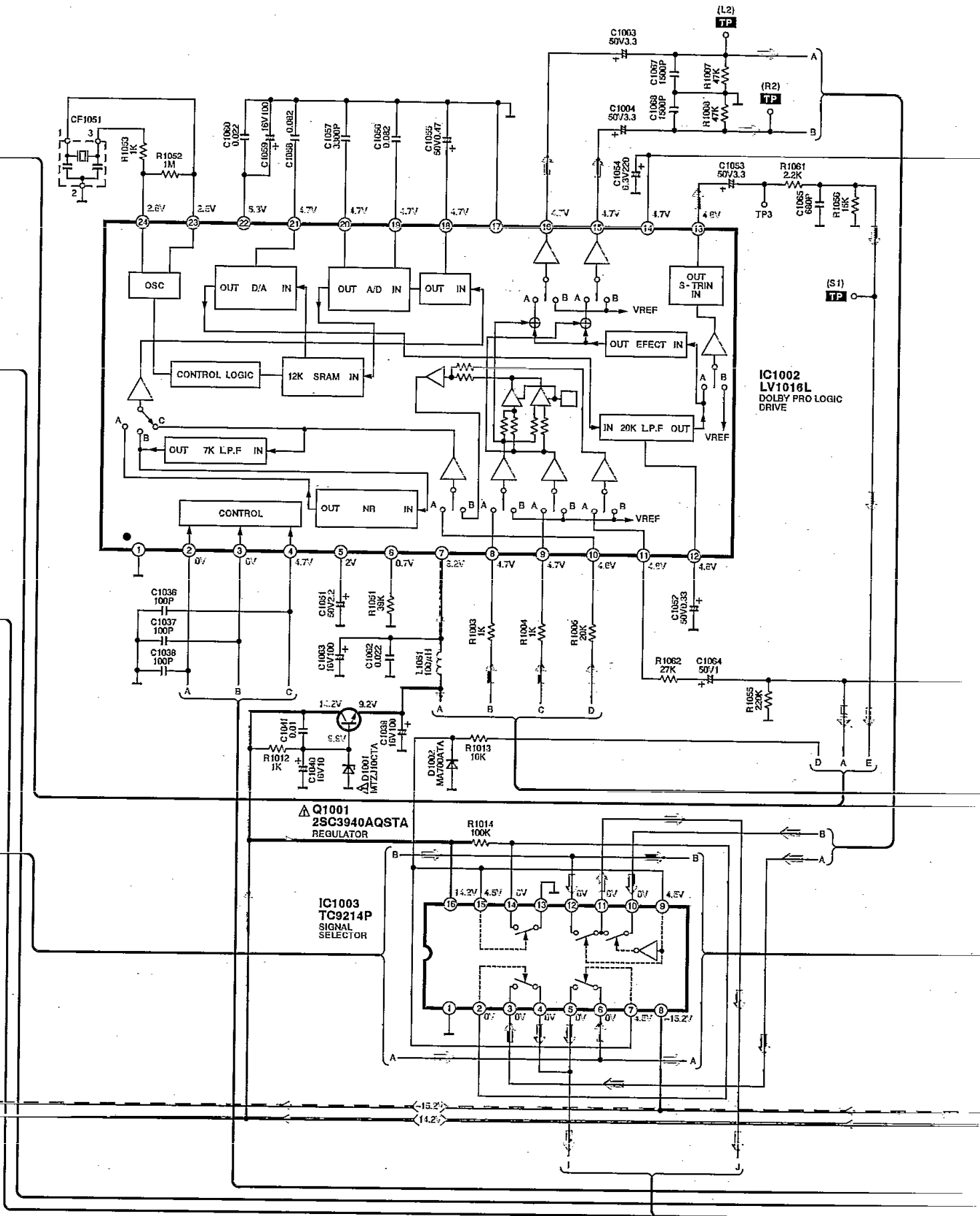

B IN/OUT TERMINAL CIRCUIT (P.C.Board: on page 44)

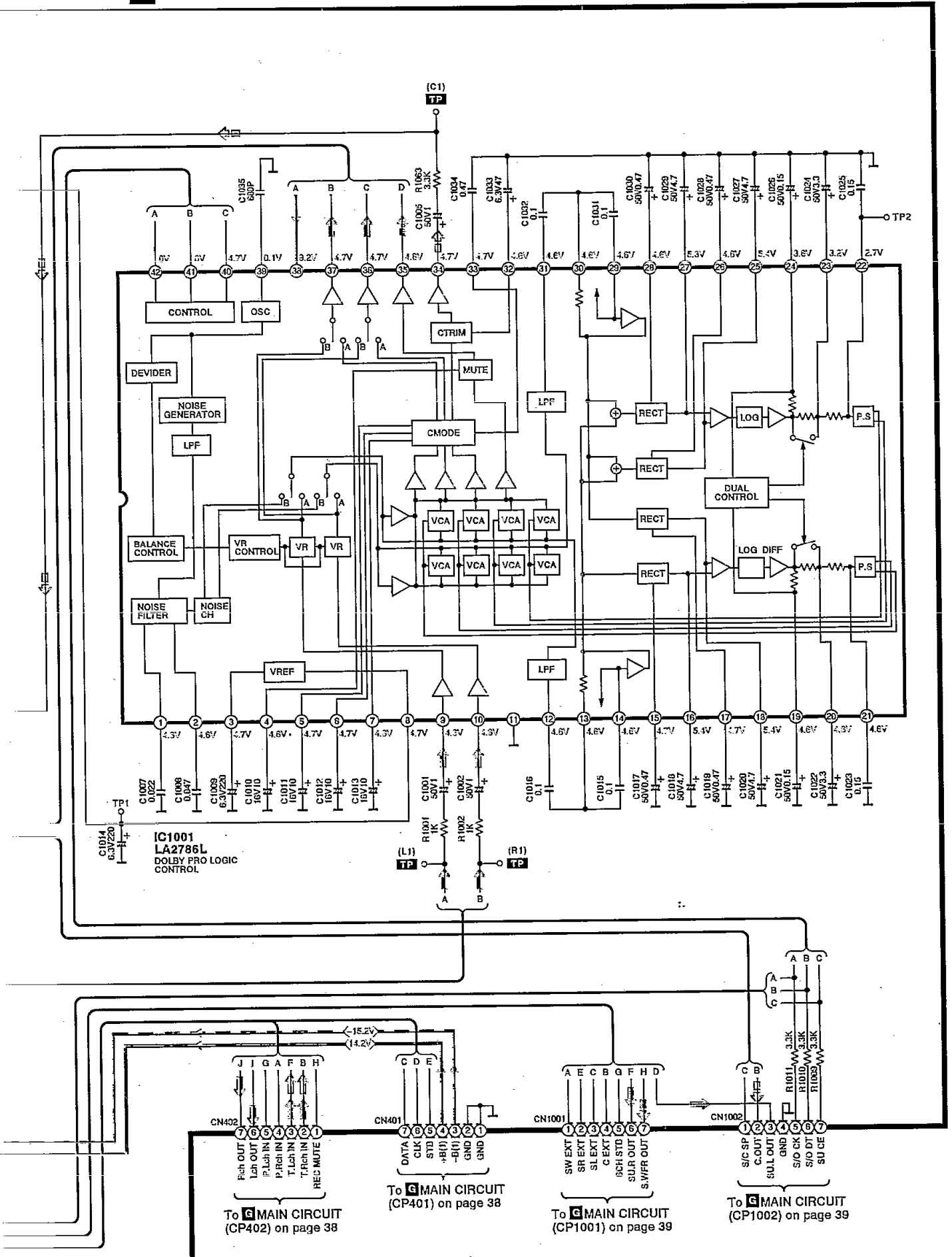

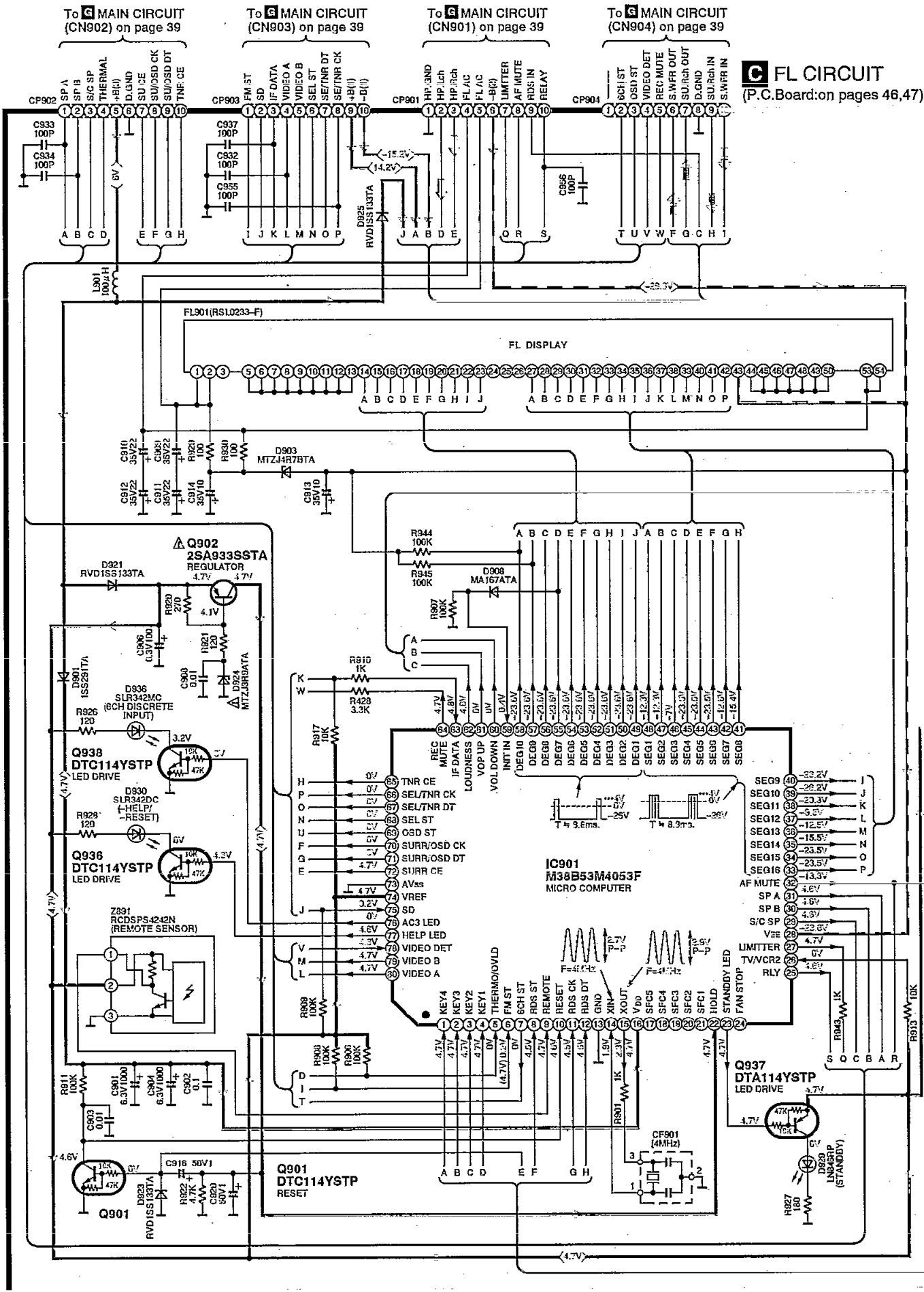

FL CIRCUIT
(P.C. Board: on pages 46,47)

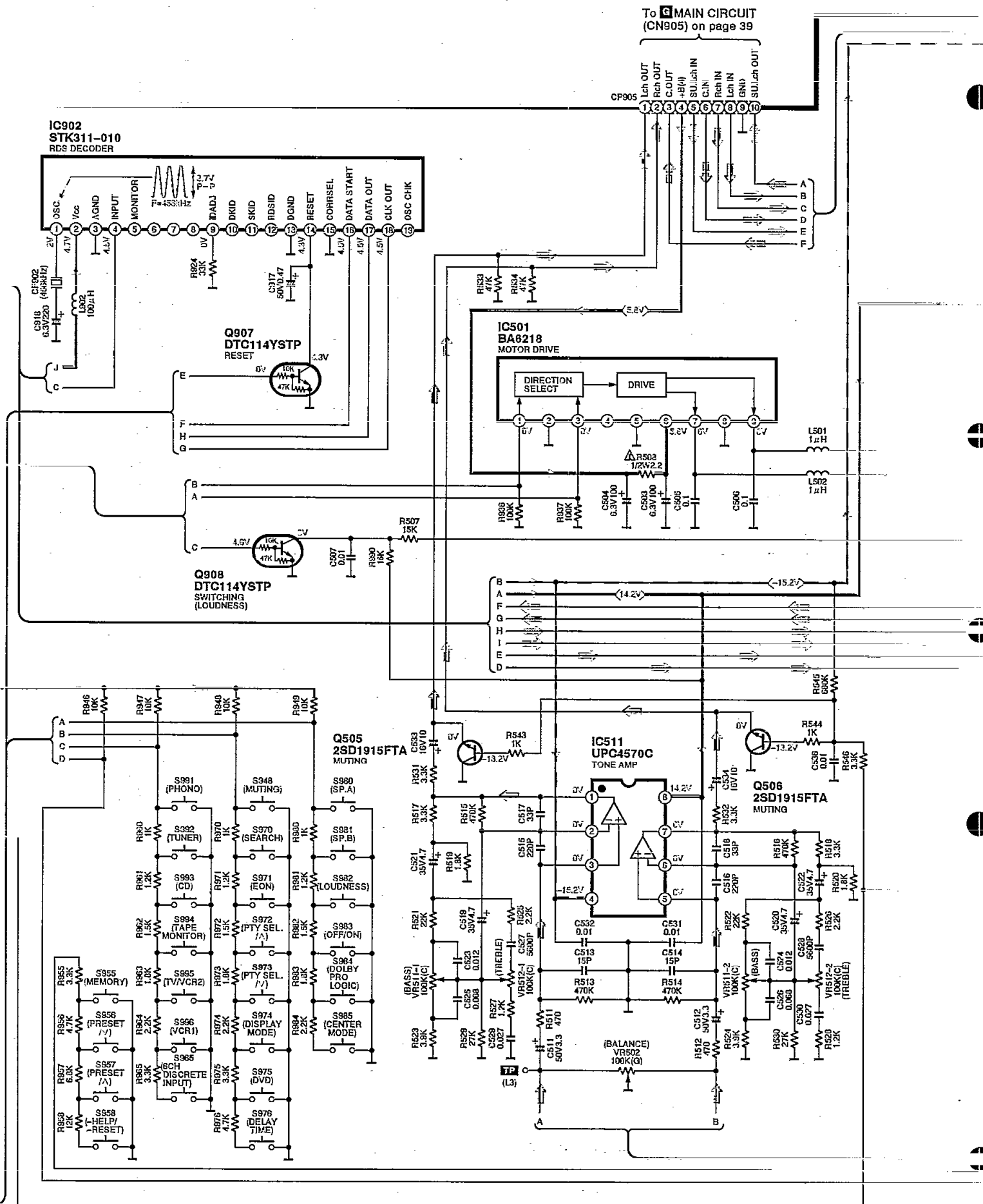

G FL CIRCUIT (P.C.Board: on pages 46,47)

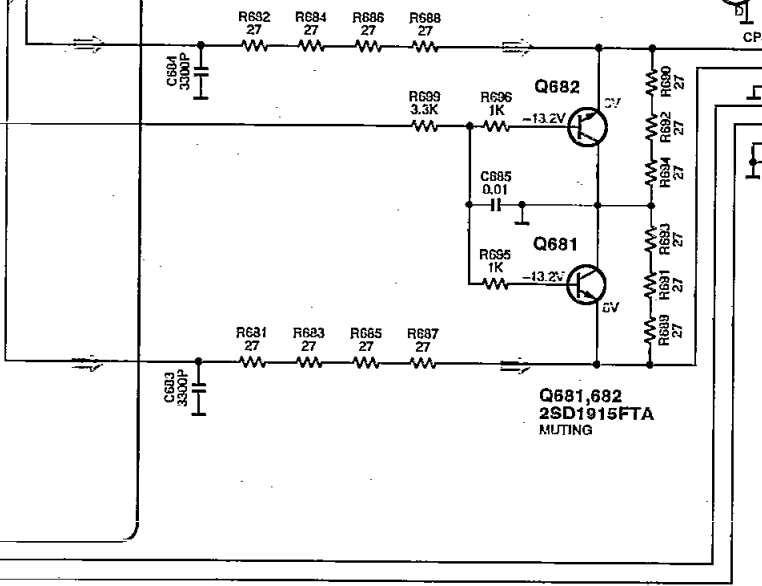
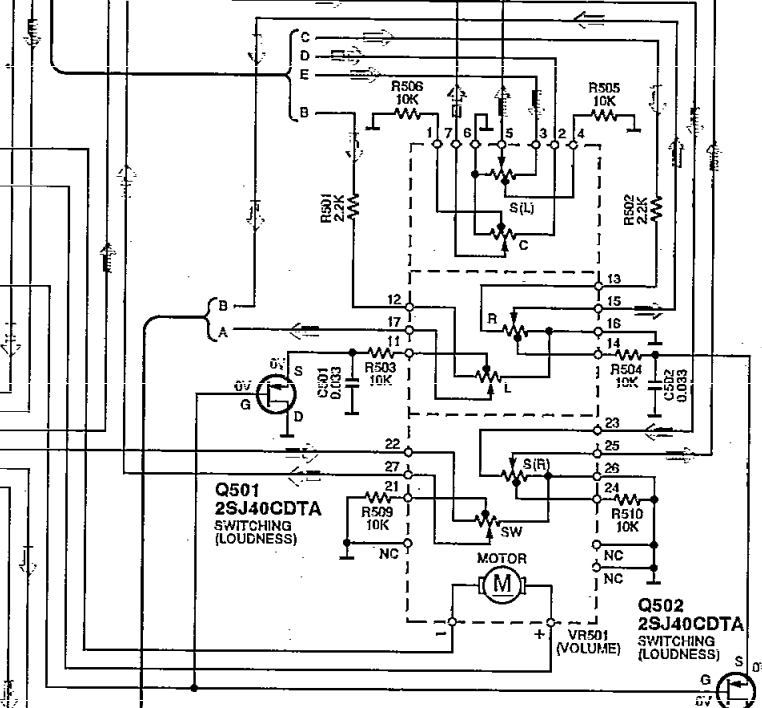
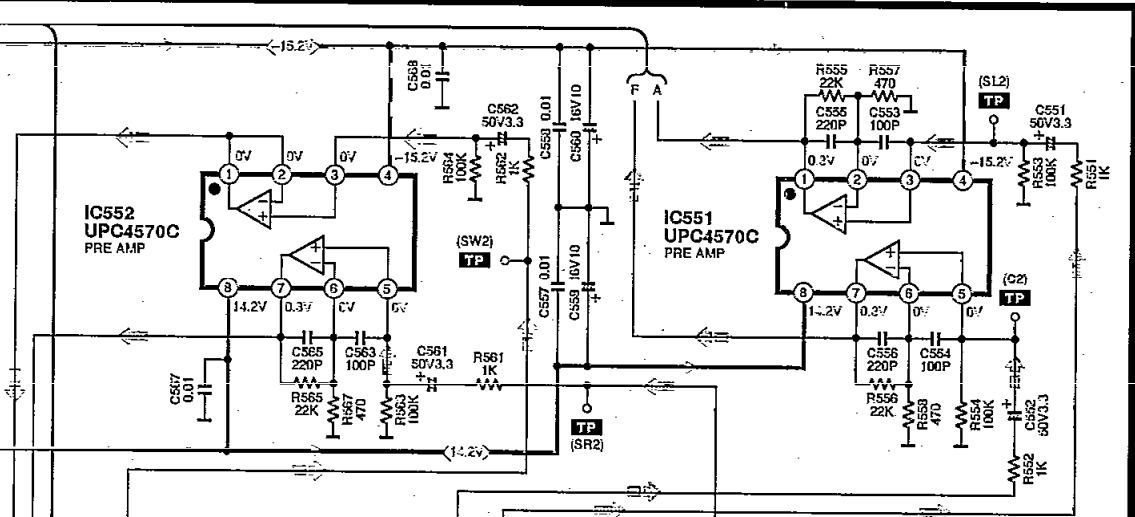

D HEADPHONES JACK CIRCUIT (P.C.Board: on page 43)

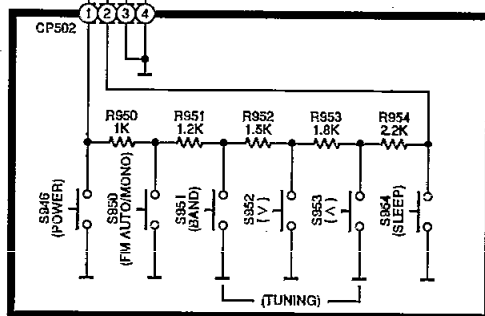
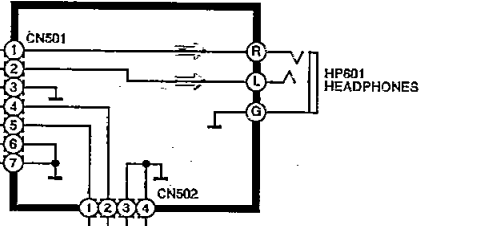

E POWER SWITCH CIRCUIT (P.C.Board: on page 43)

F SURROUND CIRCUIT (P.C.Board: on page 45)

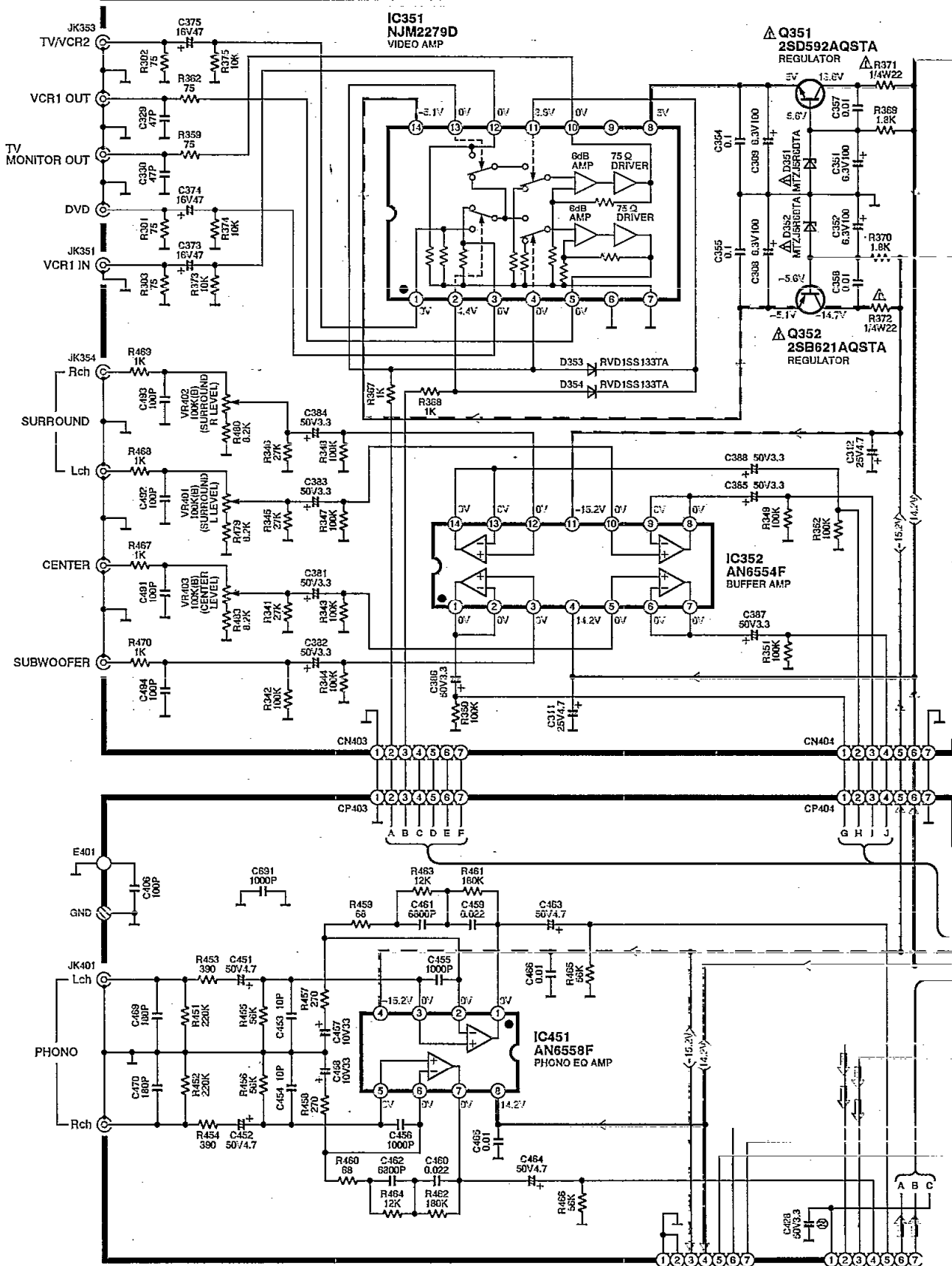

G MAIN CIRCUIT (P.C.Board: on pages 48,49)

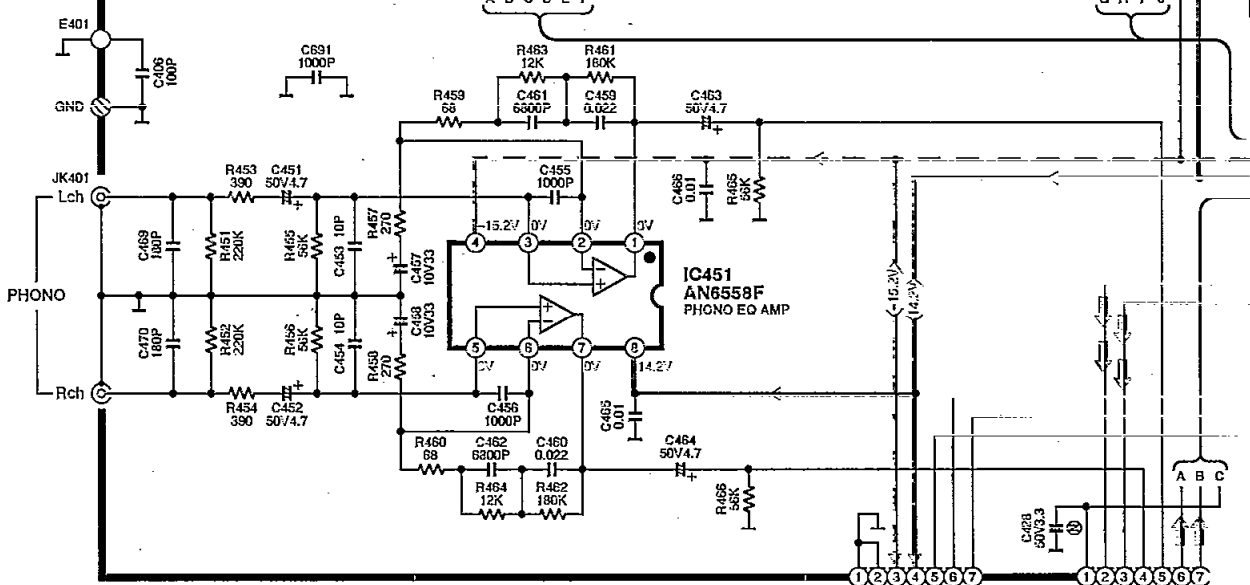

To **E** IN/OUT TERMINAL CIRCUIT (CN401) on page 34

To **B** IN/OUT TERMINAL CIRCUIT (CN402) on page 34

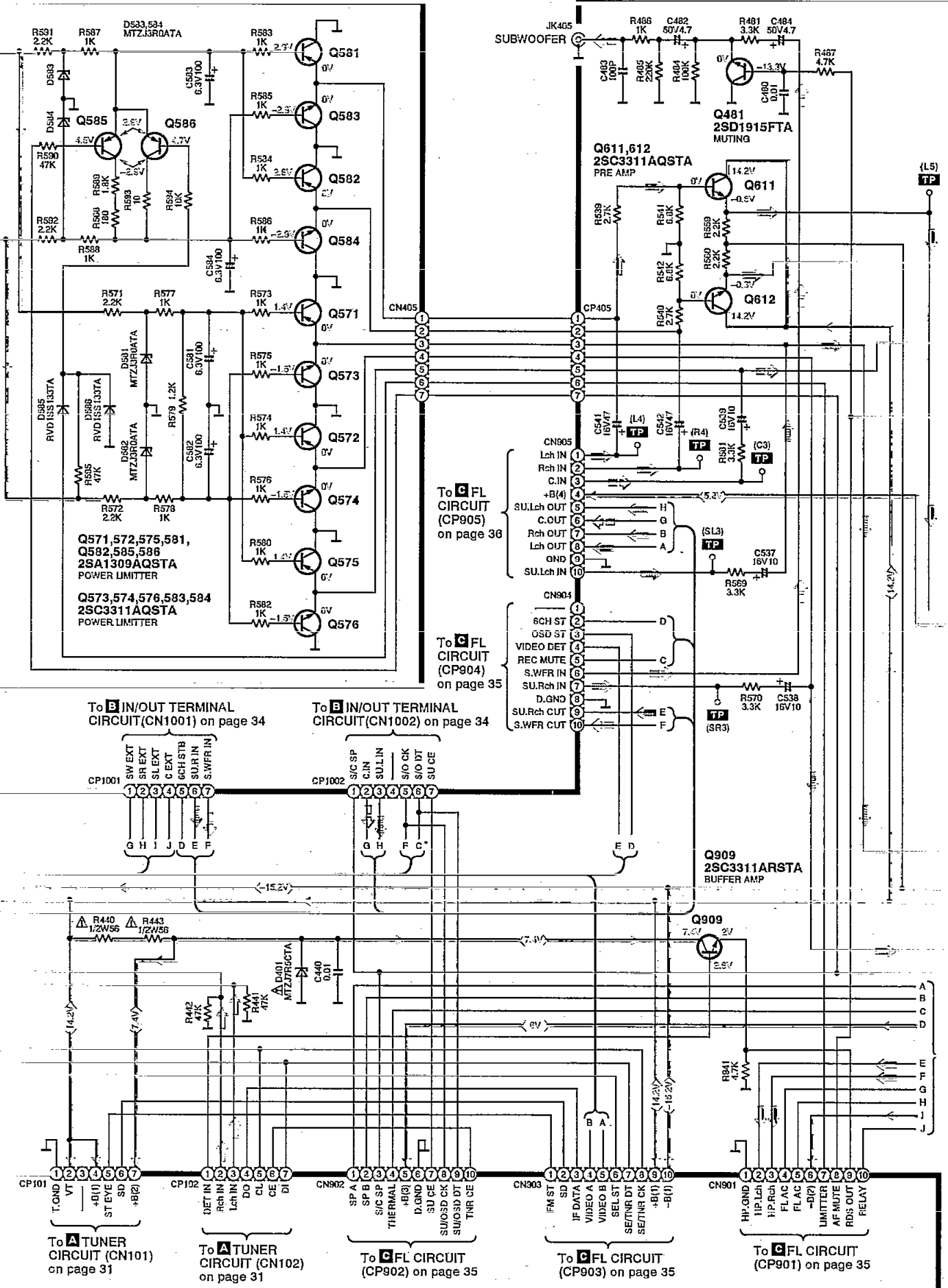

G MAIN CIRCUIT (P.C.Board: on pages 48,49)

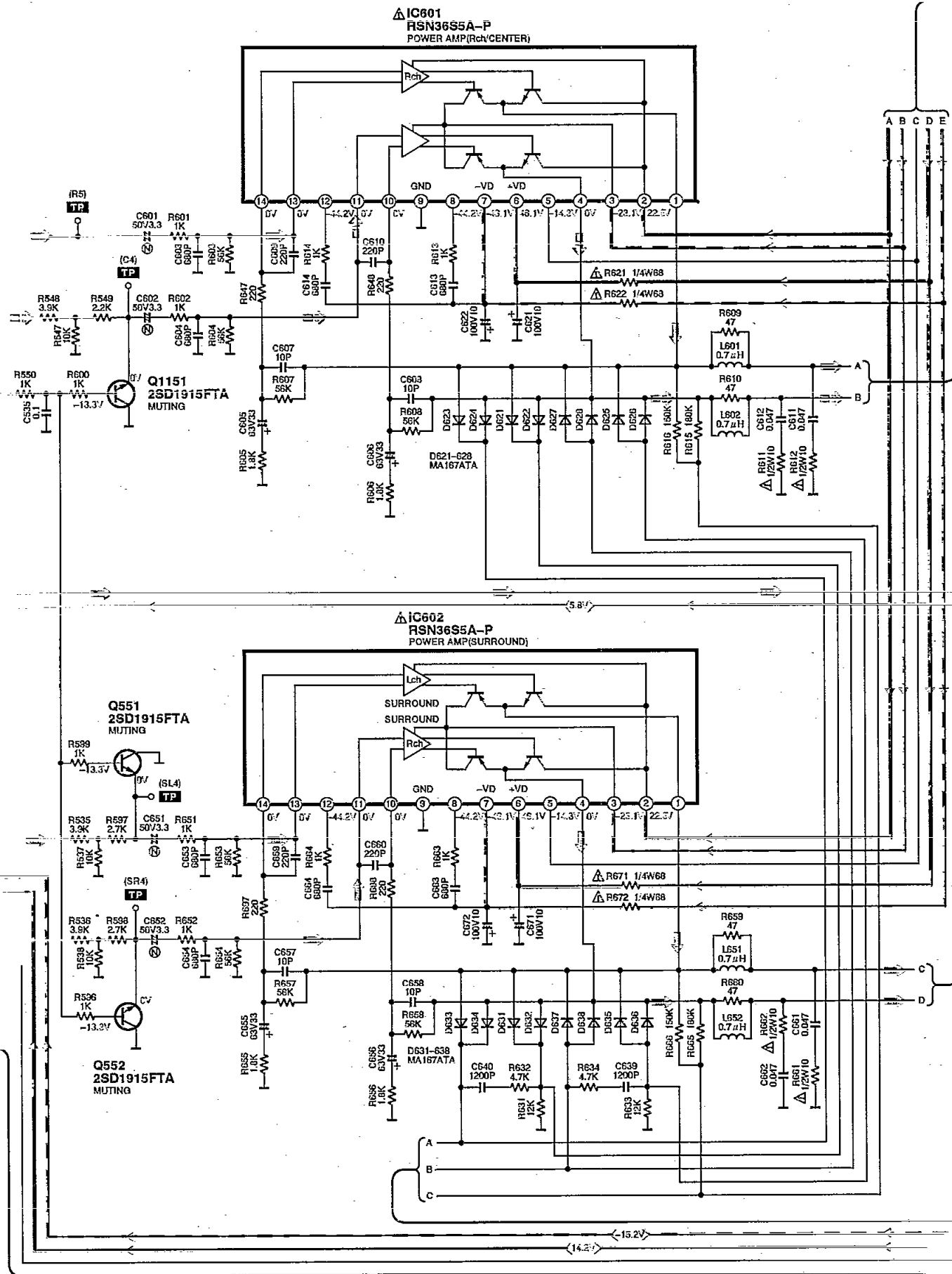

G MAIN CIRCUIT (P.C.Board: on pages 48,49)

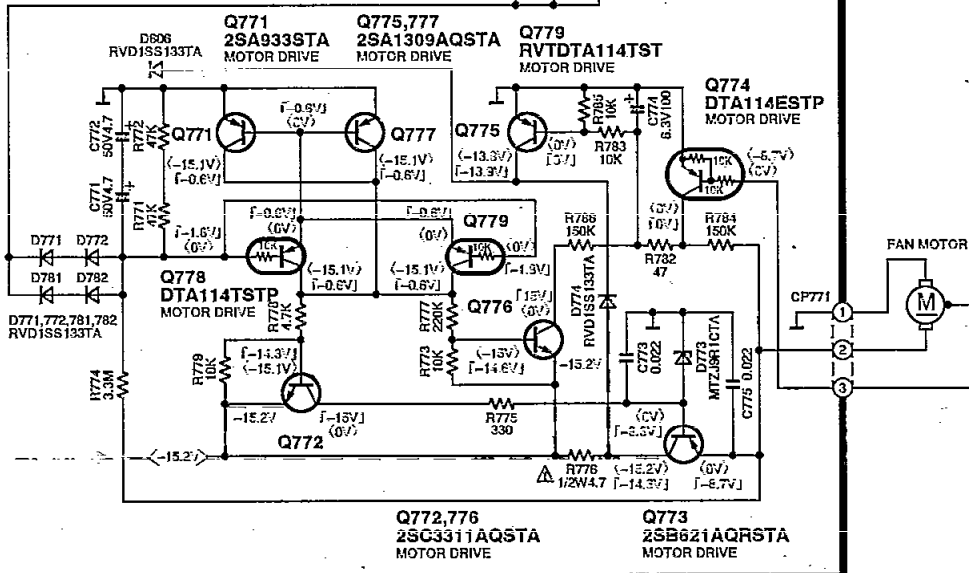
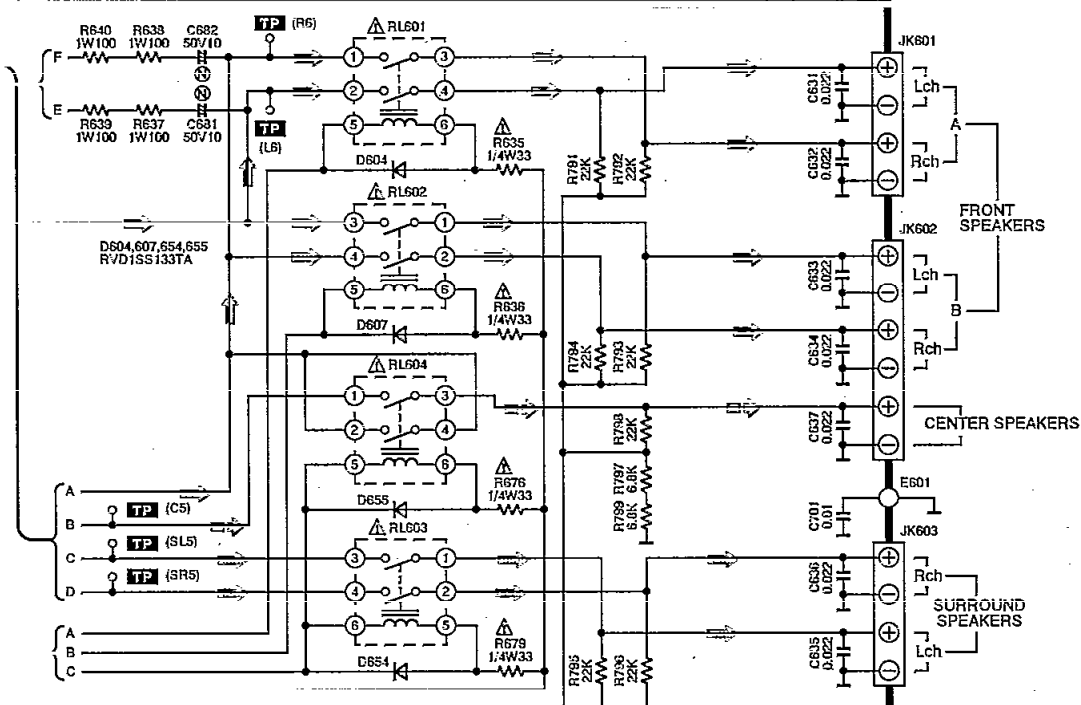

I POWER SUPPLY CIRCUIT (P.C.Board: on page 50)

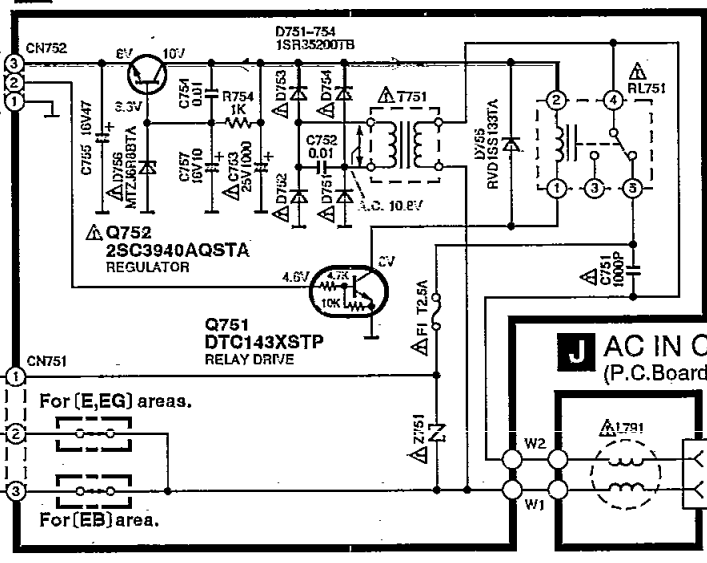

H TRANSFORMER CIRCUIT (P.C.Board: on page 50)

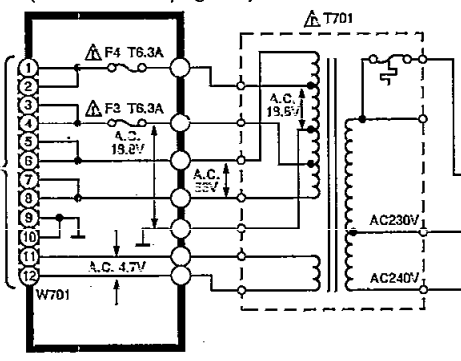

J AC IN CIRCUIT (P.C.Board: on page 50)

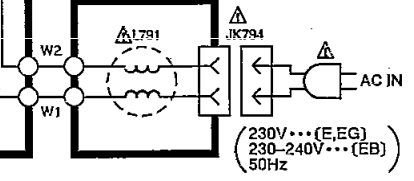

Printed Circuit Board Diagram

• This circuit board diagram may be modified at any time with the development of new technology.

A TUNER P.C.B.

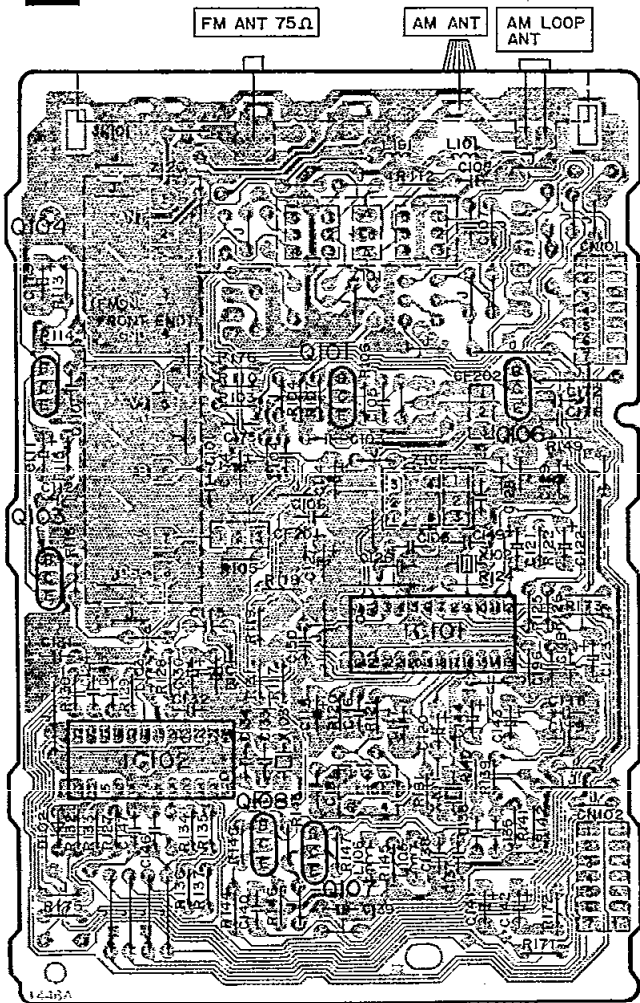

REP2158A-T**[EG]
 REP2158D-T**[E,EB]

D HEADPHONES JACK P.C.B.

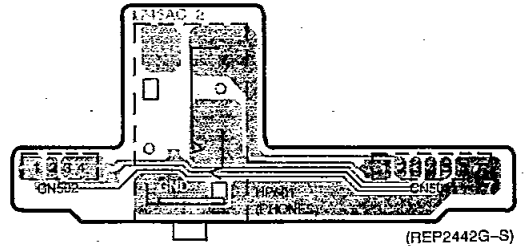

(REP2442G-S)

E POWER SWITCH P.C.B.

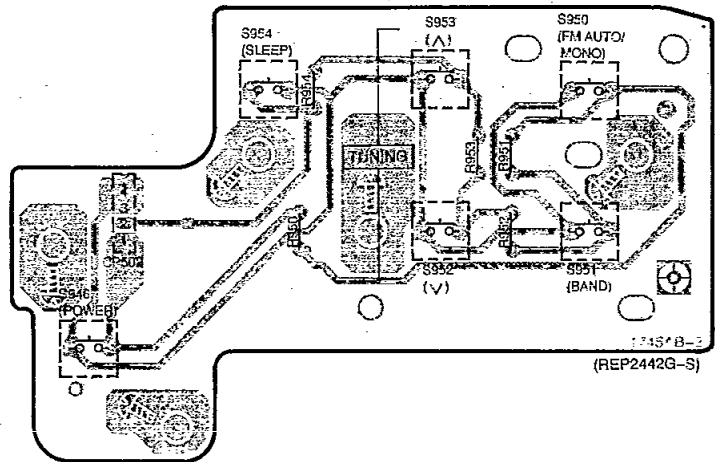

(REP2442G-S)

B IN/OUT TERMINAL P.C.B.

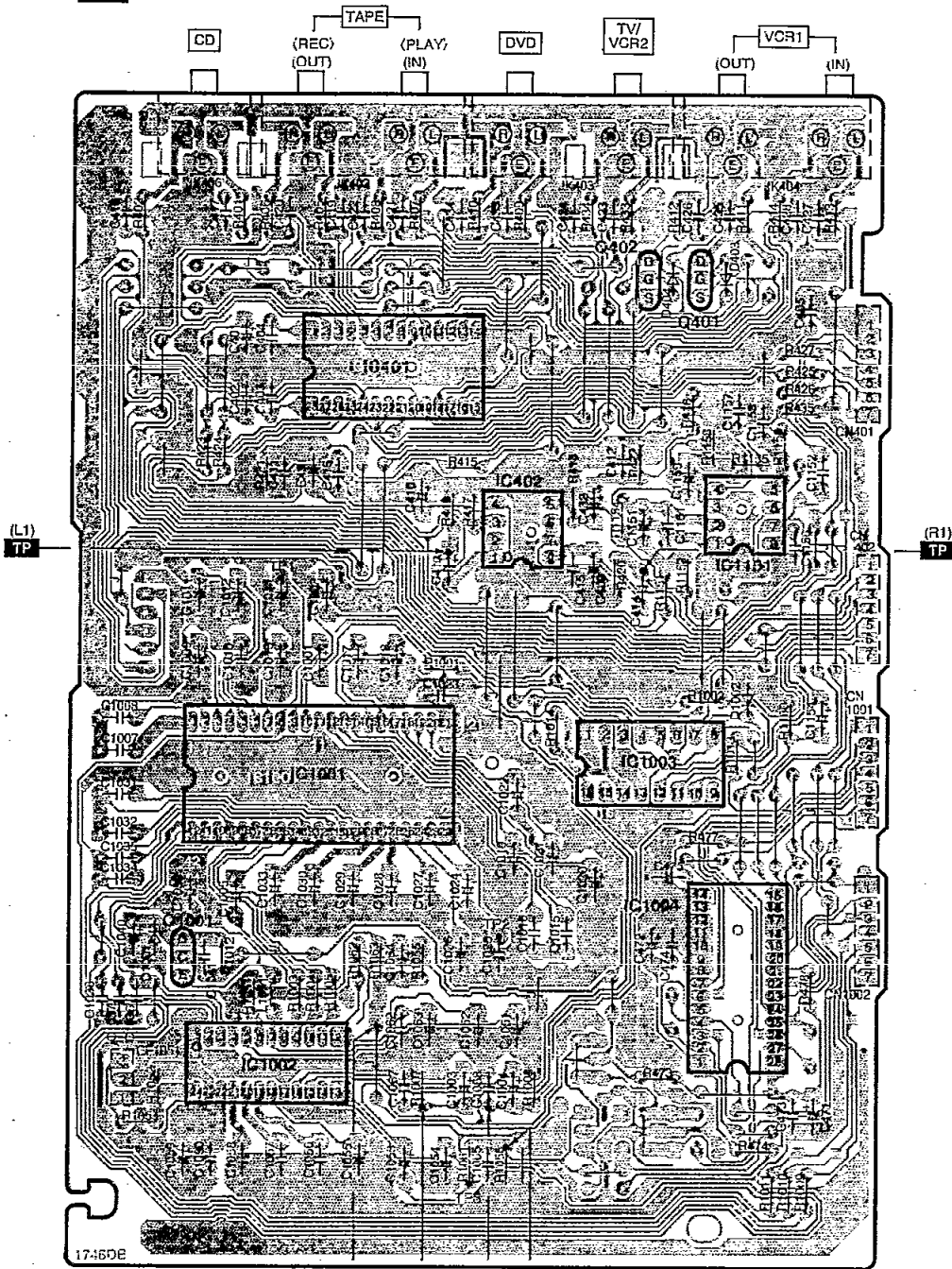

(REP2443L-P...[E,EG])
 (REP2443M-P...[EB])

TP (C1) TP (L2) TP (R2) TP (S1)

F SURROUND P.C.B.

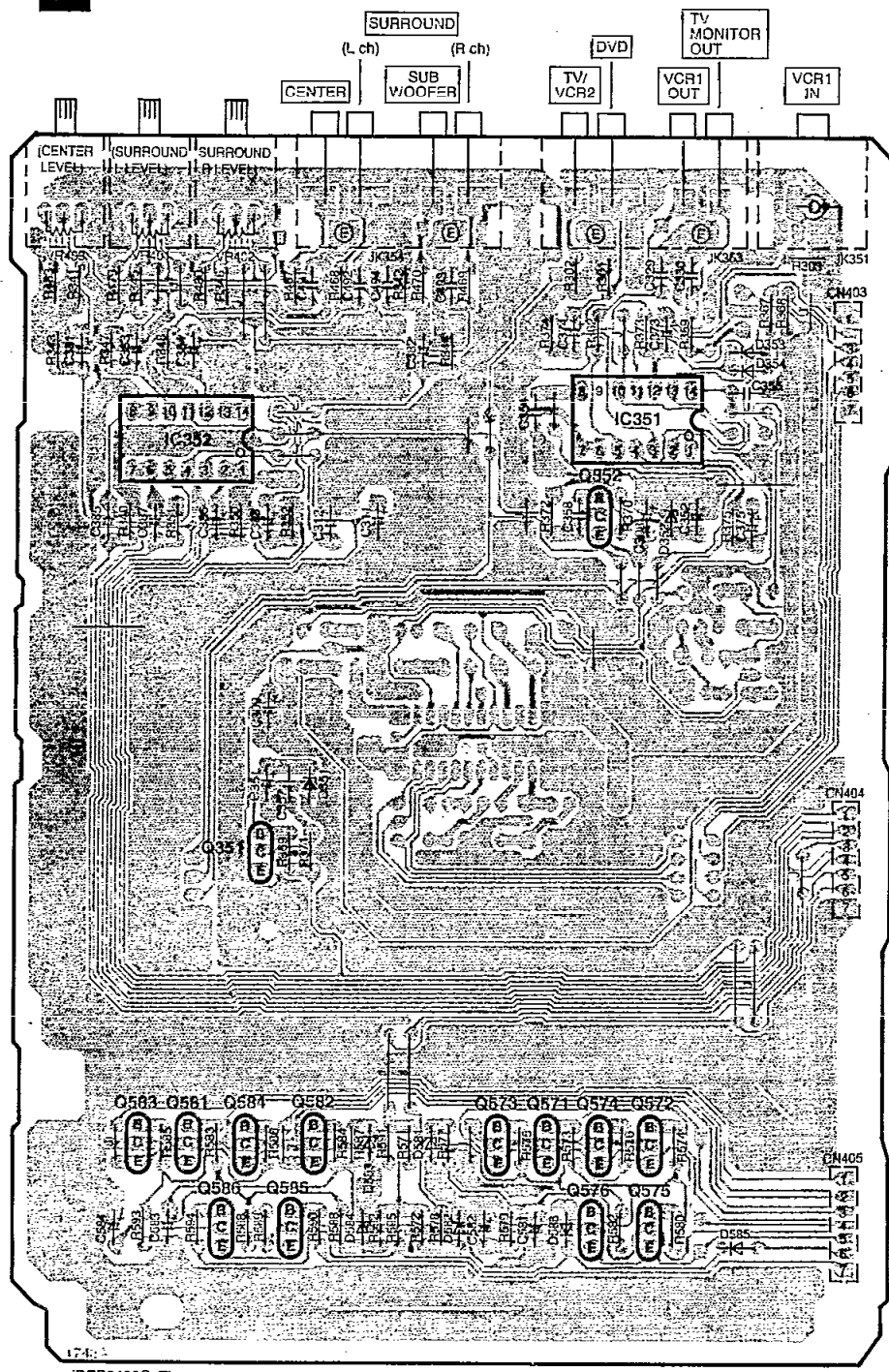

(C2)
TP

(SL2)
TP

C FL P.C.B.

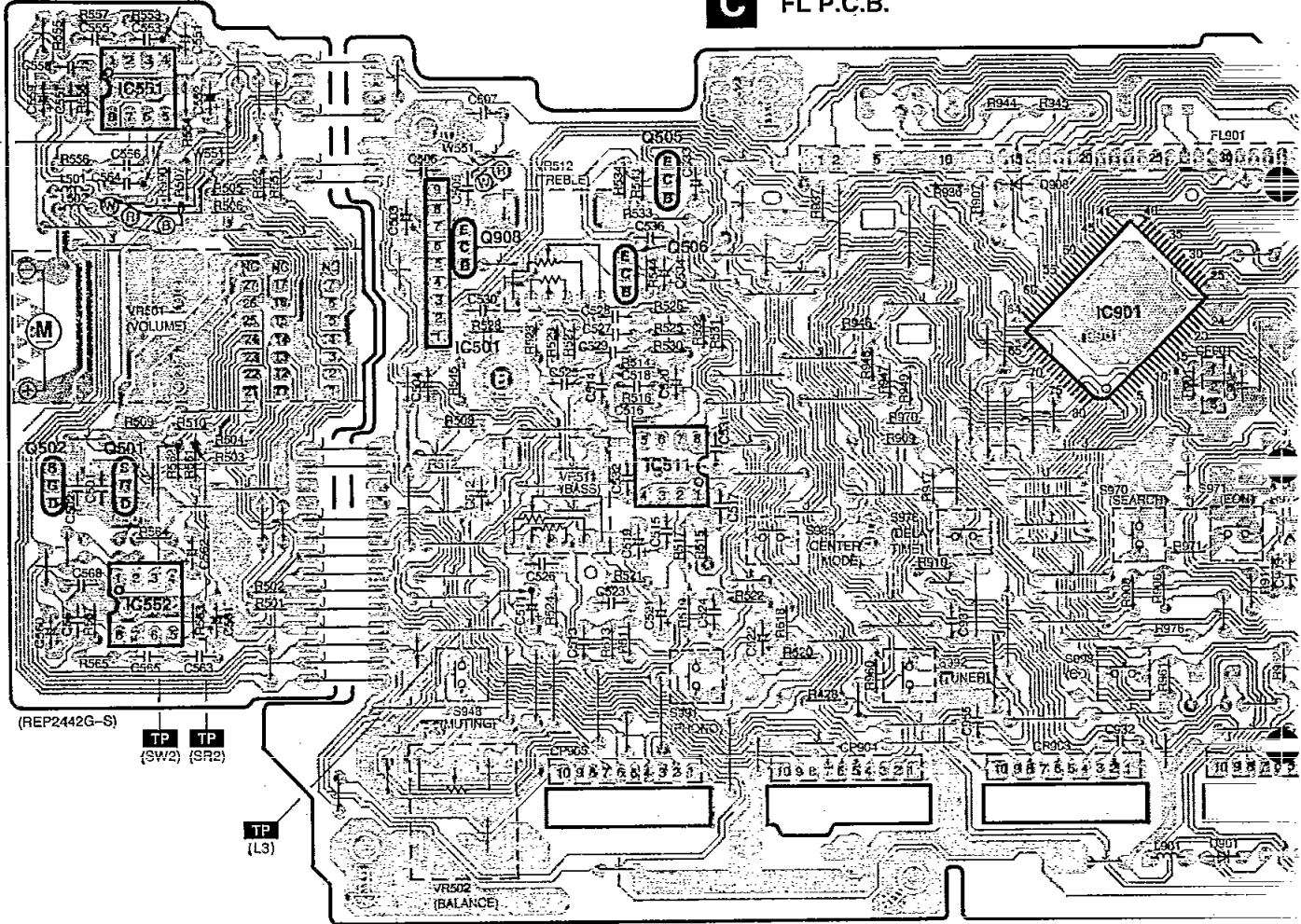

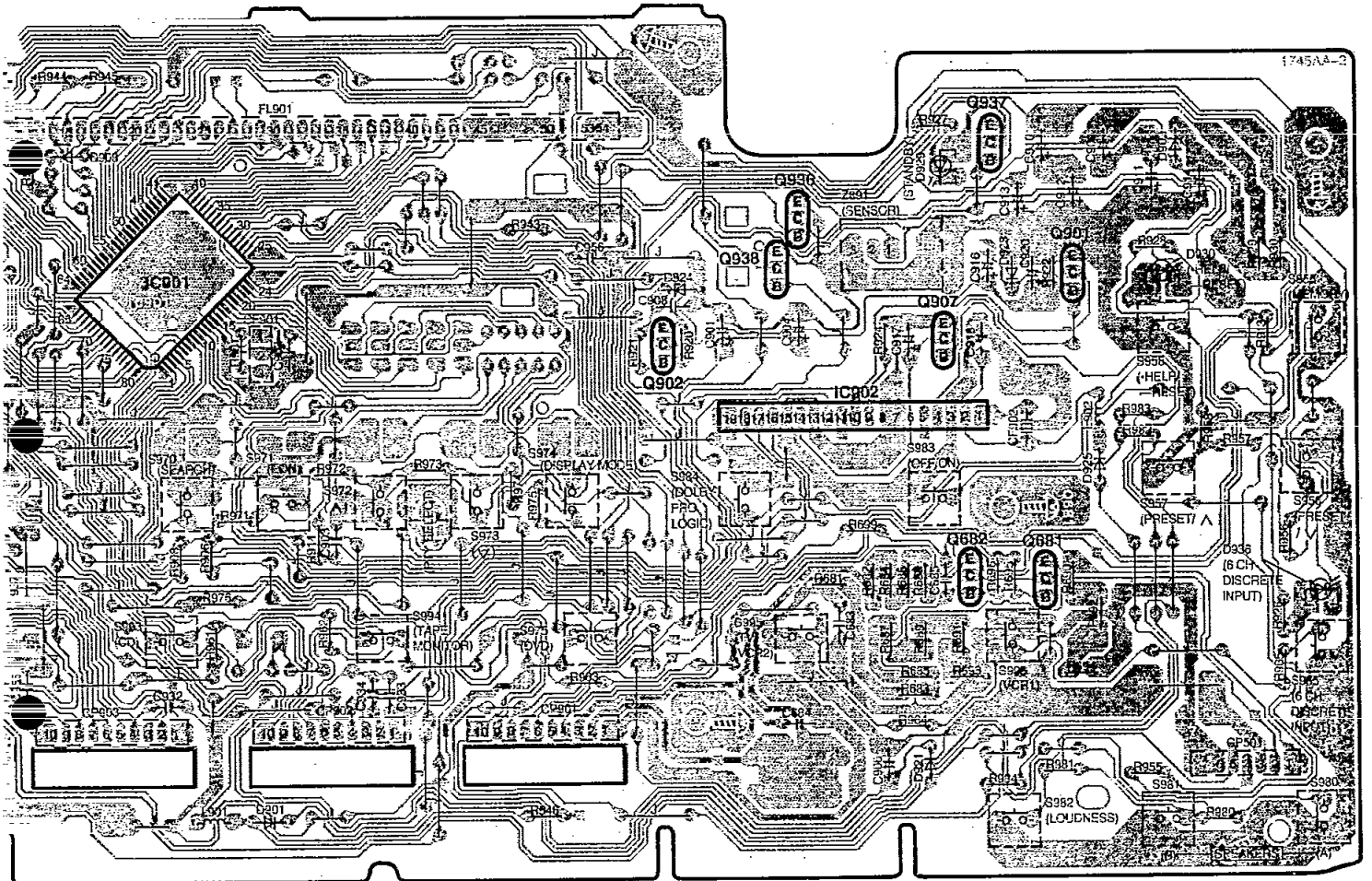

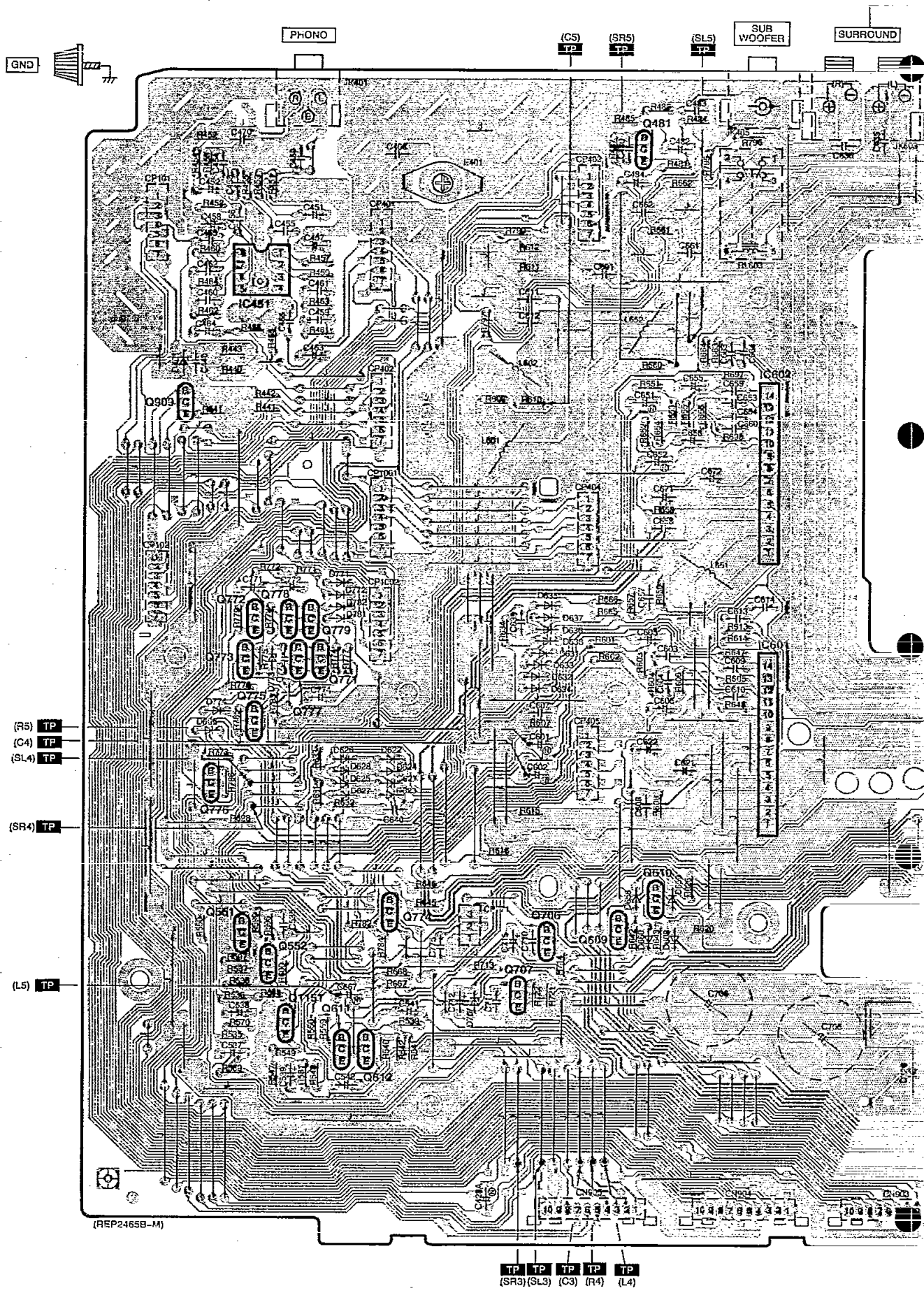

(REP2465B-M)

TP	TP	TP	TP	TP
(SR3)(SL3)	(C3)	(R4)	(L4)	

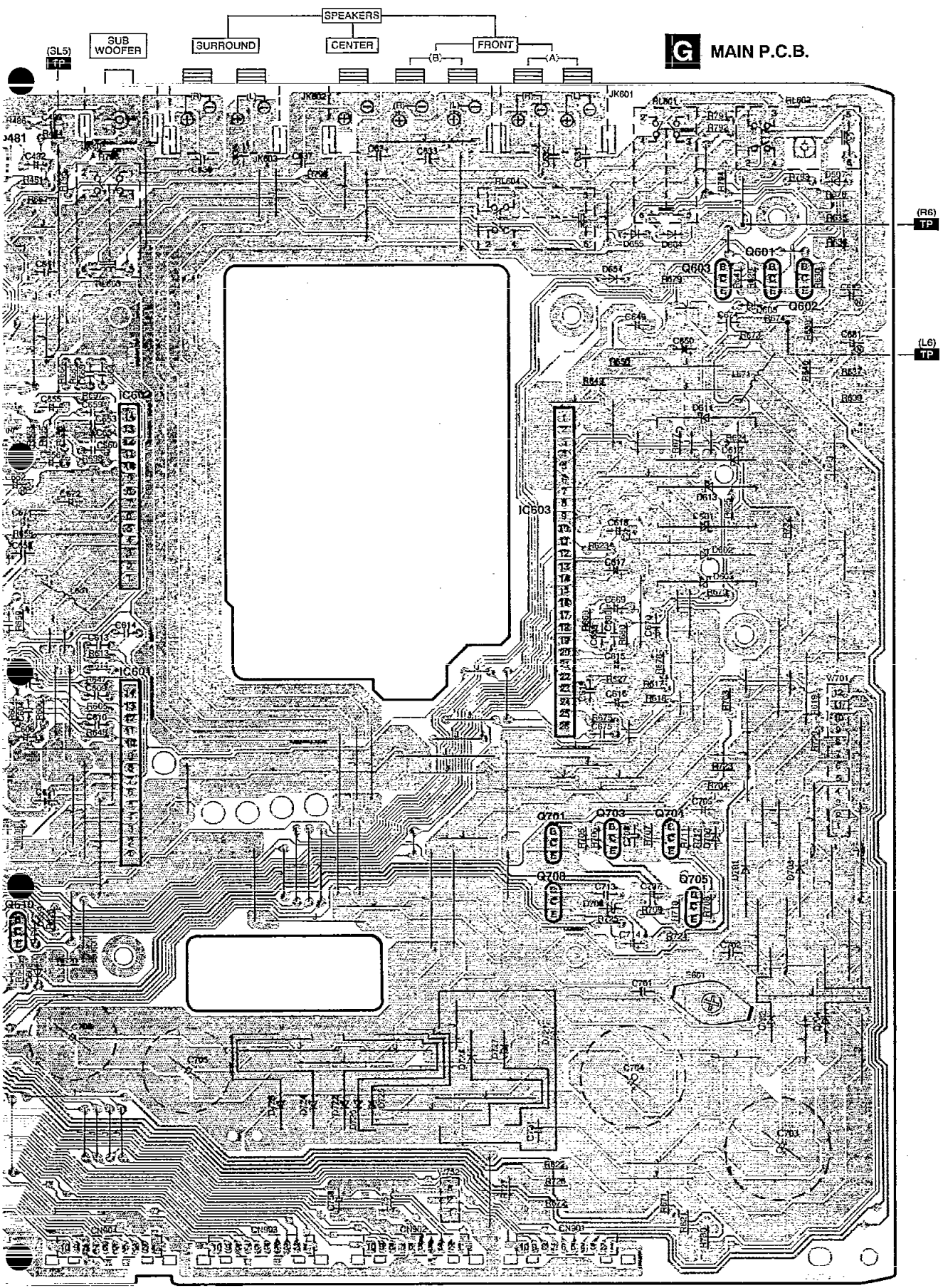

G MAIN P.C.B.

I POWER SUPPLY P.C.B.

H TRANSFORMER P.C.B.

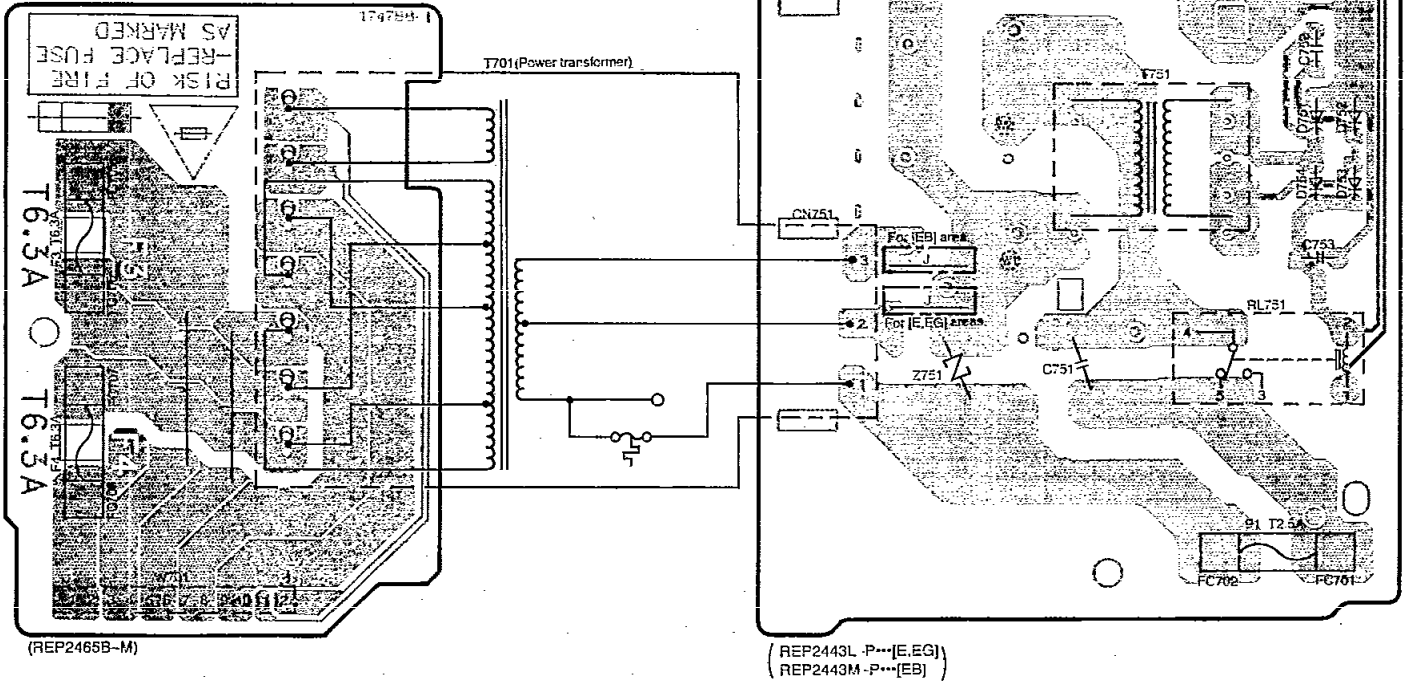

J AC IN P.C.B.

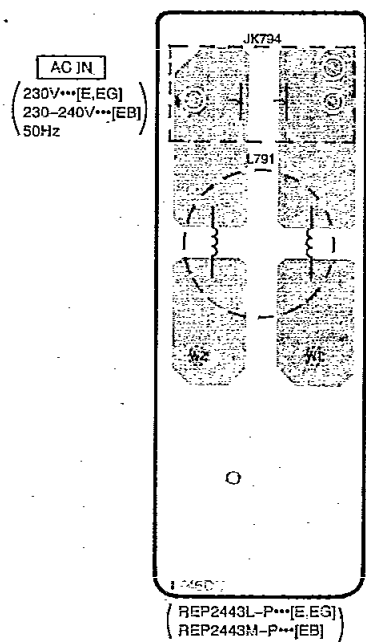

Wiring Connection Diagram

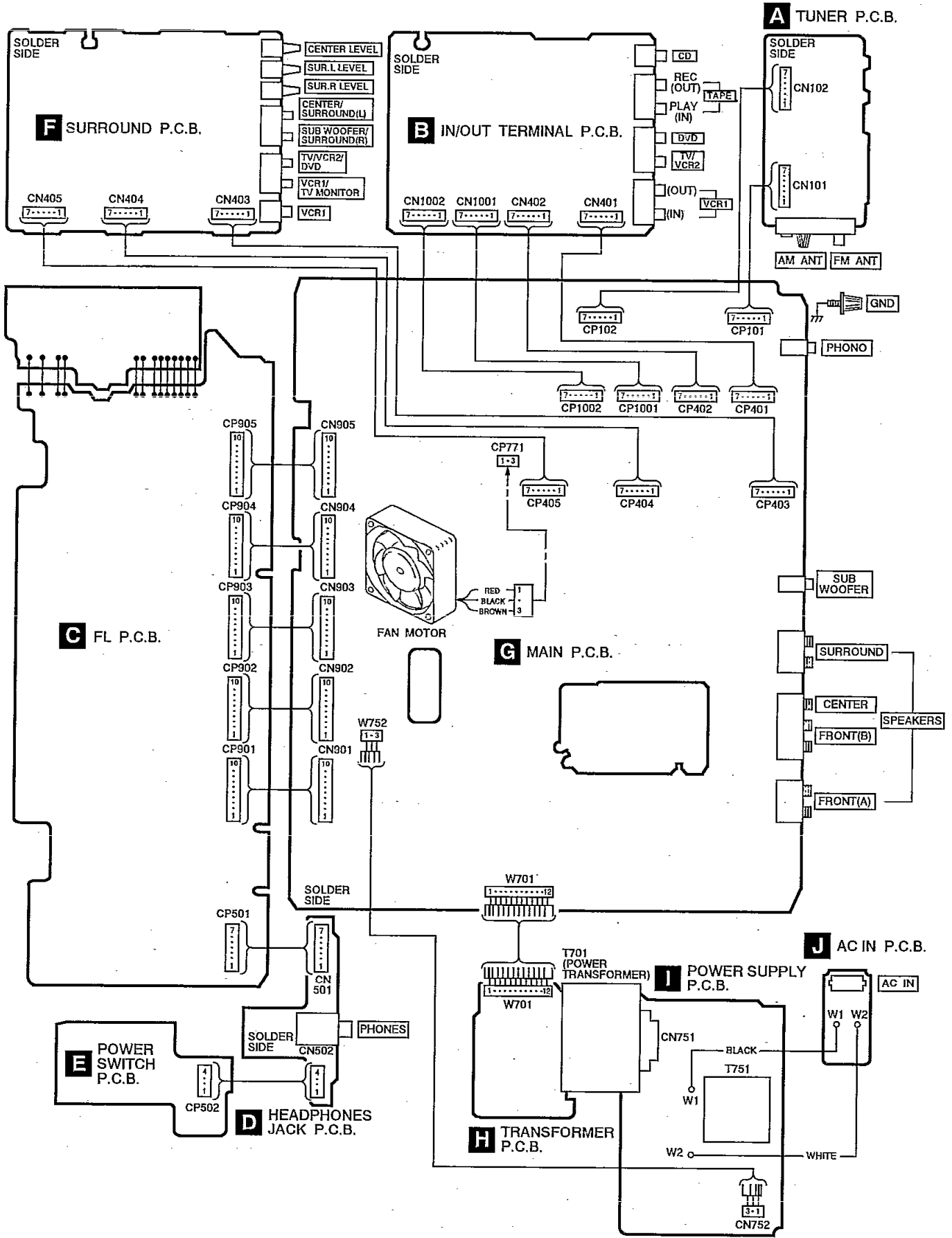

Block Diagram

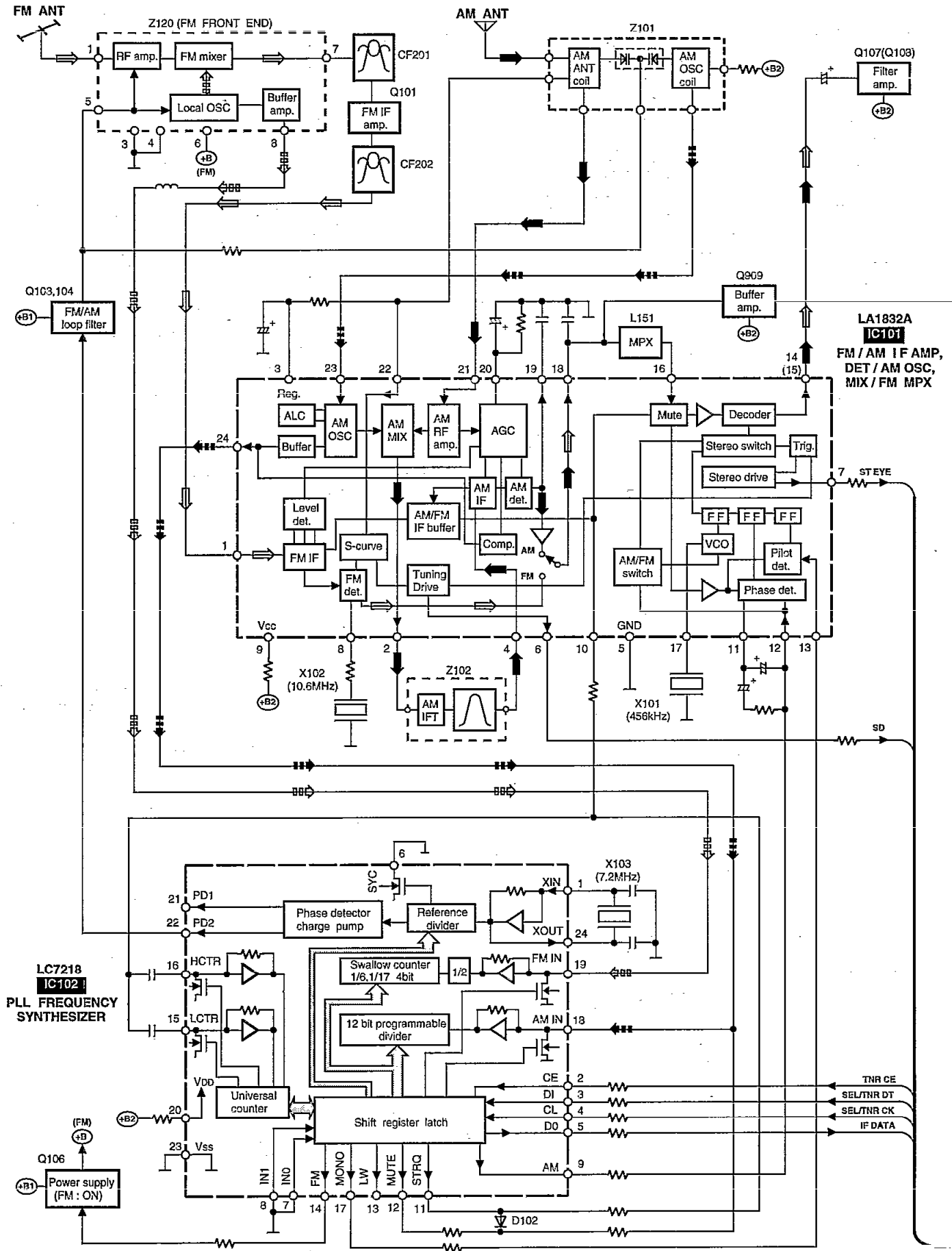

STK311-010
IC902
 RDS DECODER

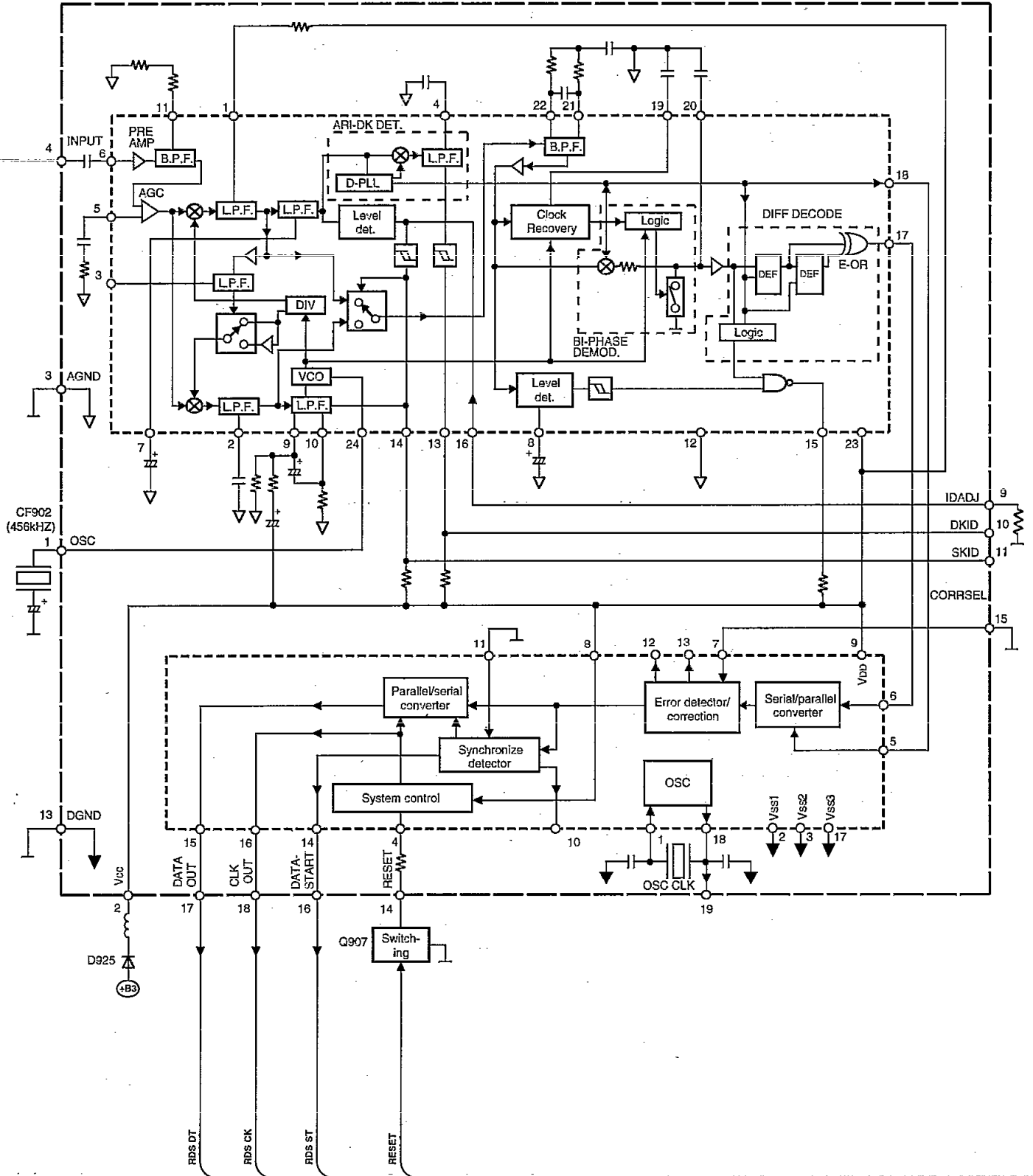

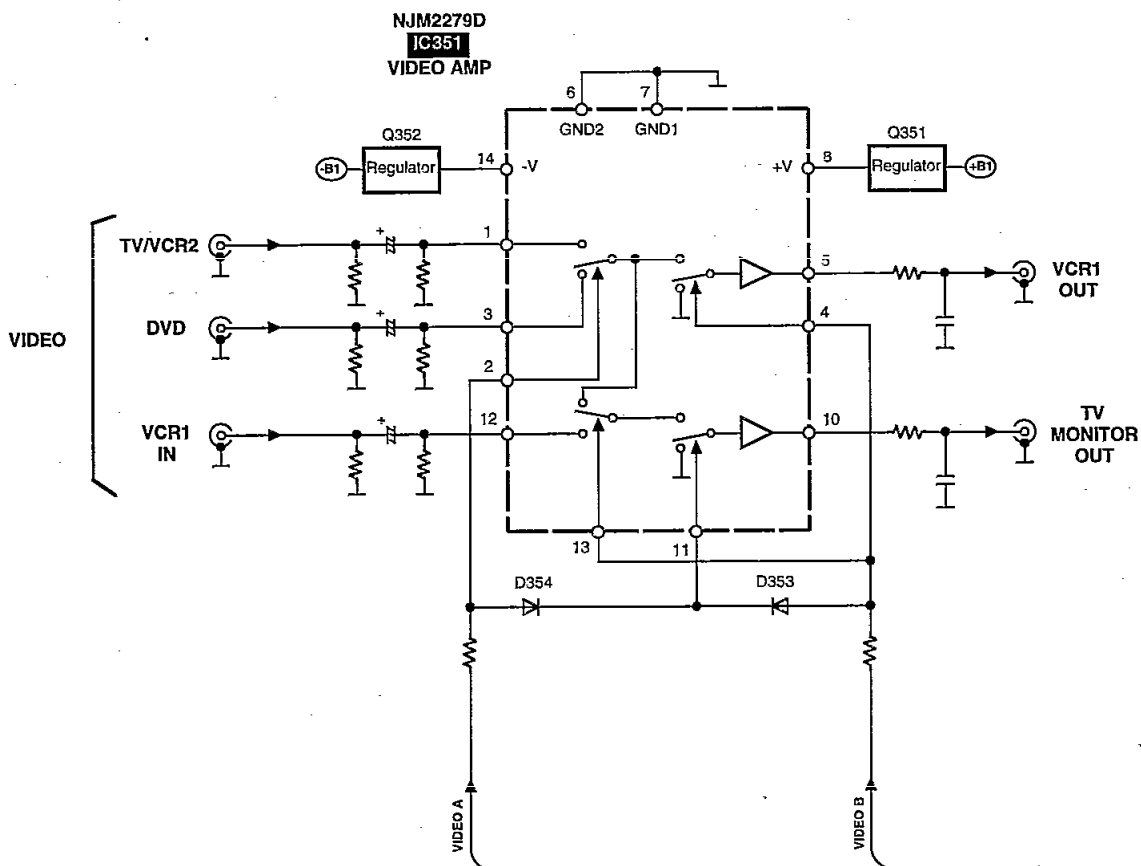
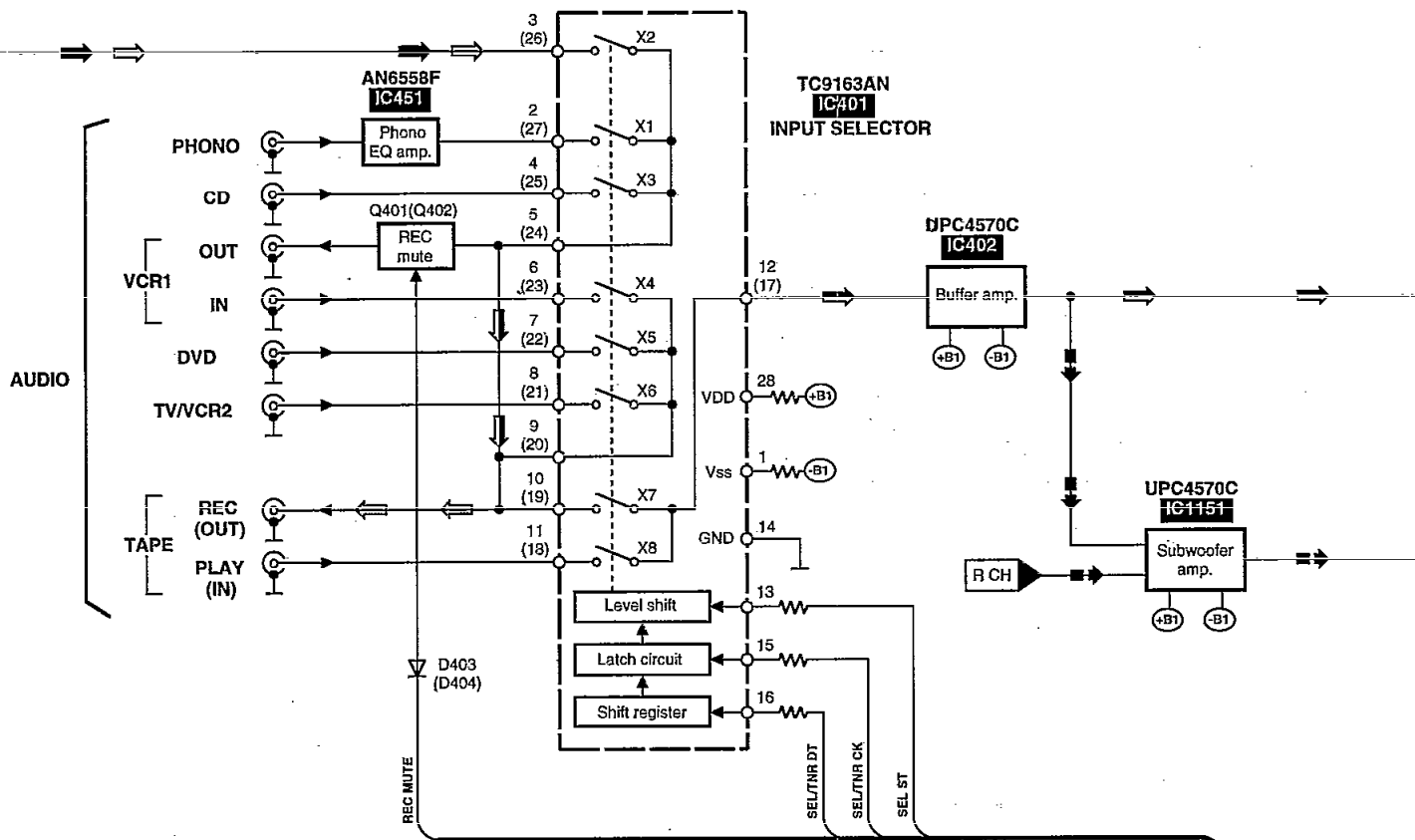

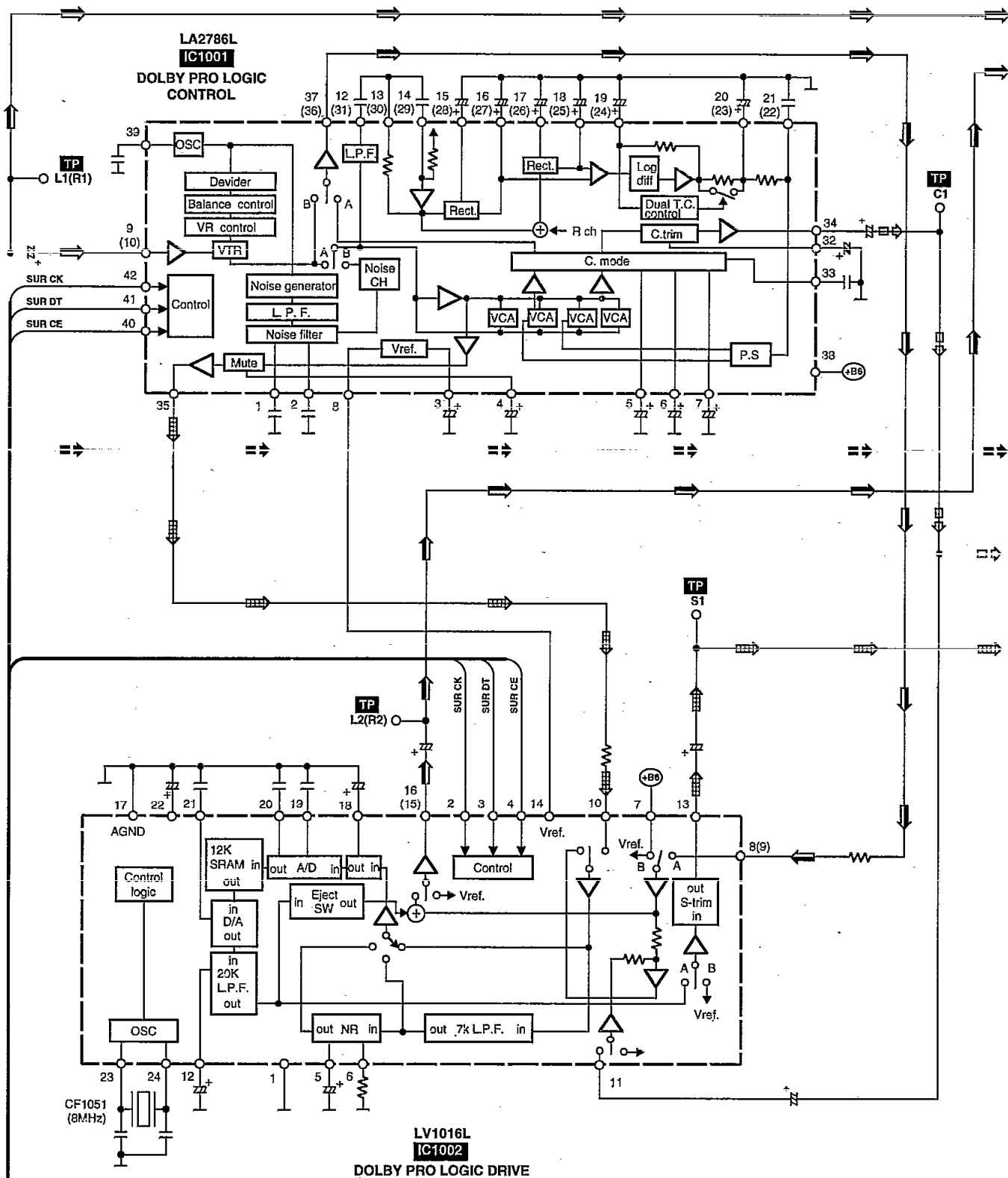

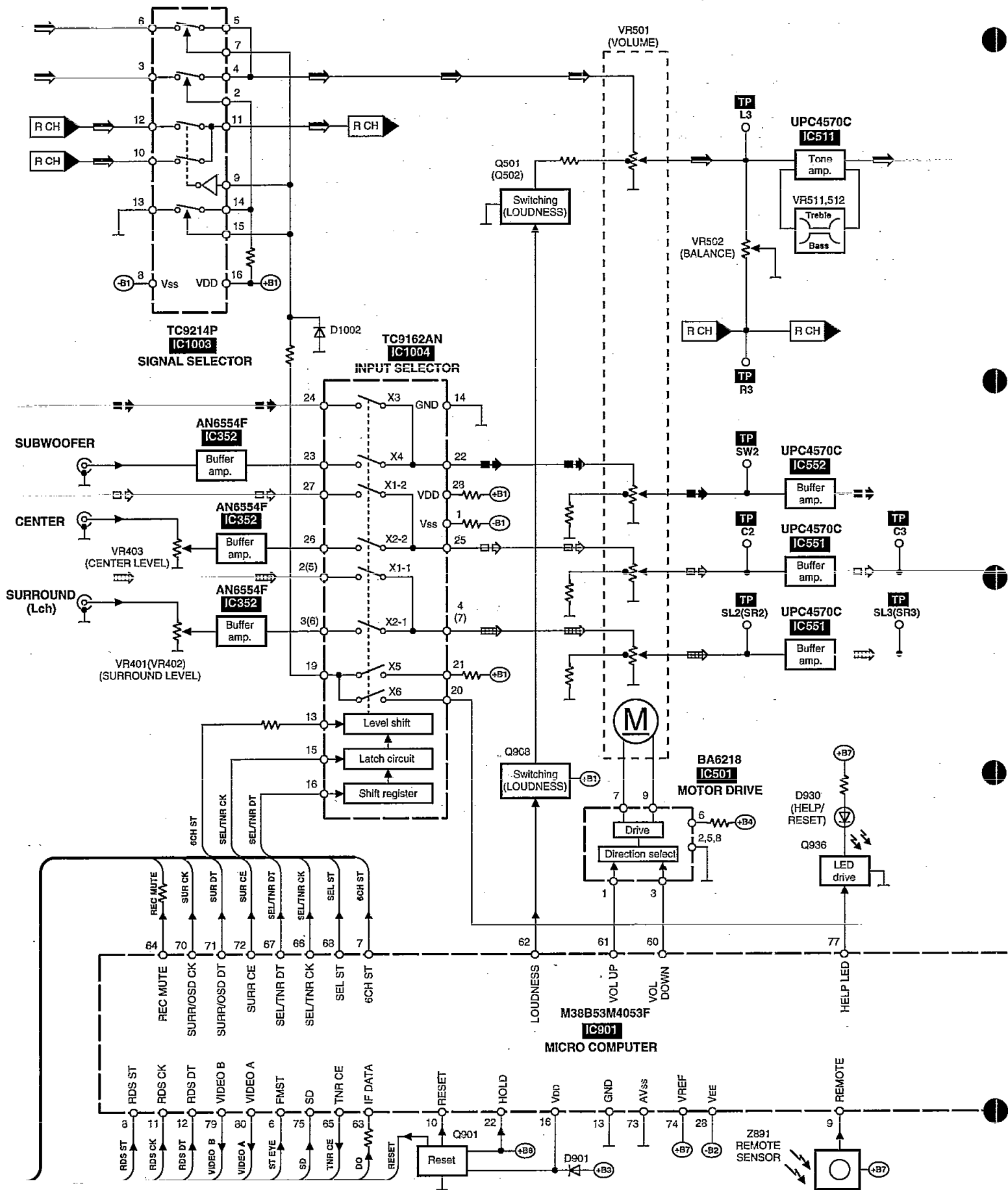

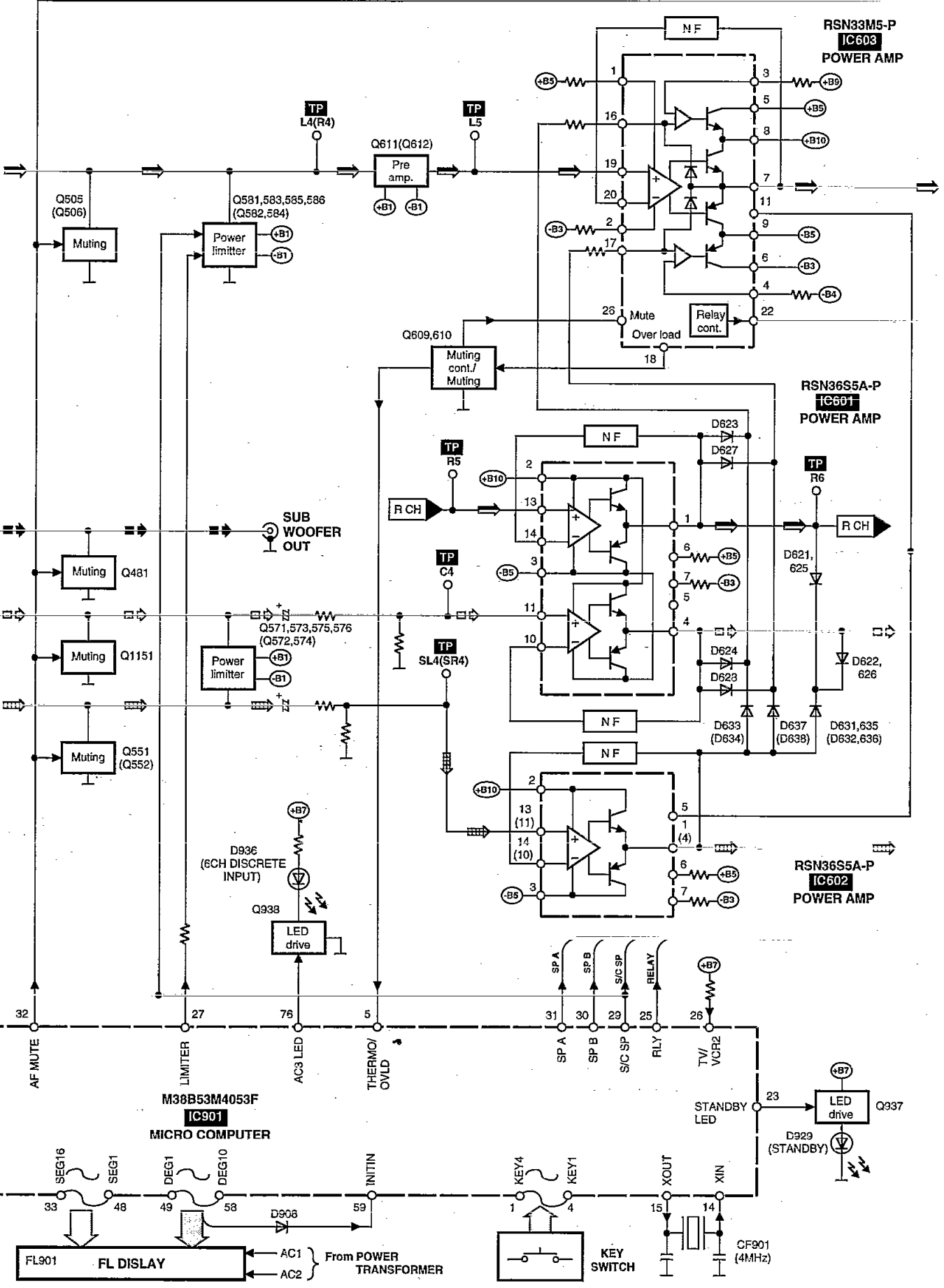

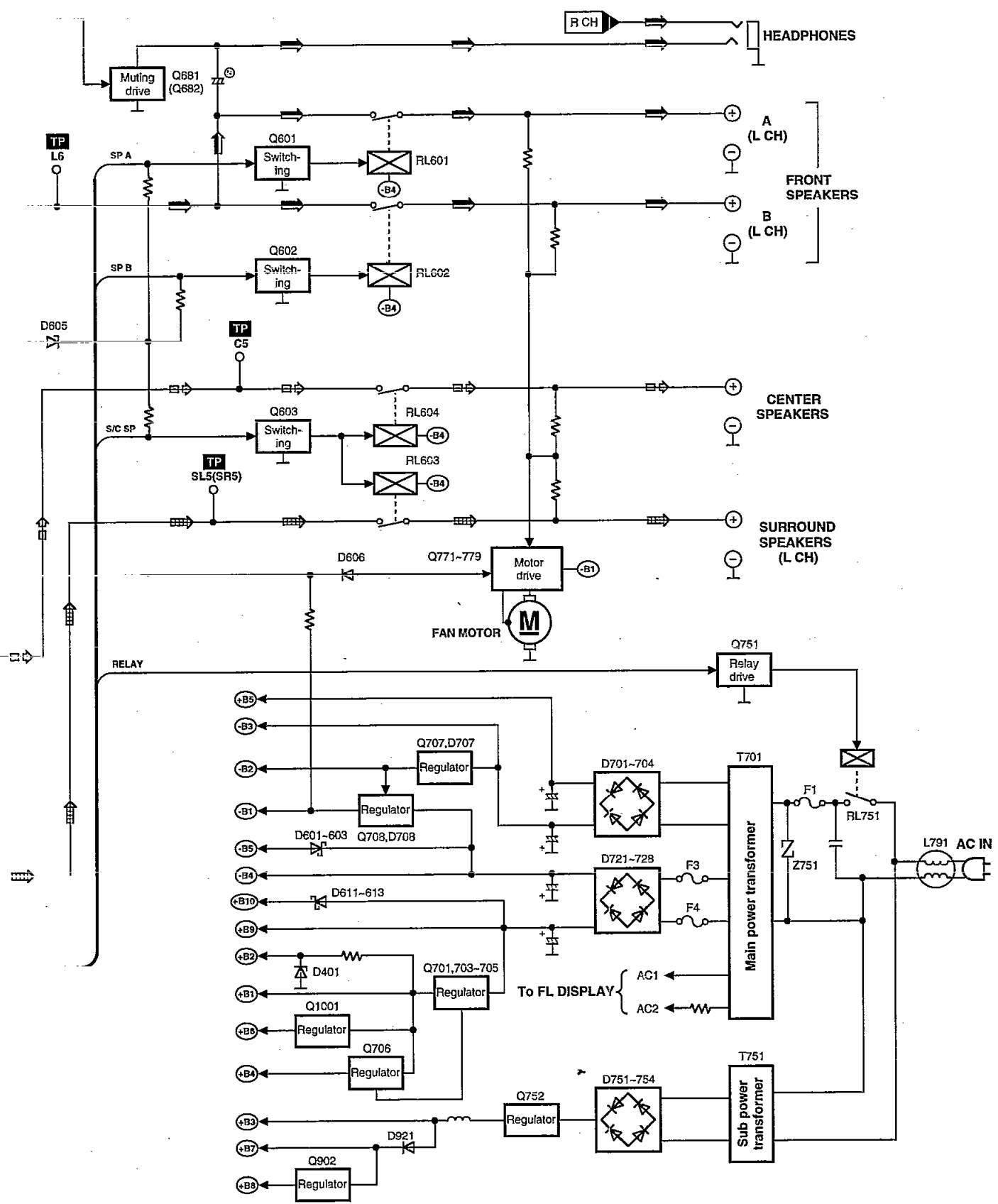

Notes

1) \square : FM signal \Rightarrow : AM signal \square : FM OSC signal \Rightarrow : AM OSC signal
 \Rightarrow : Main signal \Rightarrow : REC out signal \square : Center speaker drive signal
 \Rightarrow : Surround speaker drive signal \Rightarrow : Subwoofer speaker drive signal

2) () indicates pin No. Right channel.

Ref. No.	Part No.	Part Name & Description	Pcs	Remarks	Ref. No.	Part No.	Part Name & Description	Pcs	Remarks
CN502	RJU100W04	CONNECTOR (4P)	1	[W]	1C451	AN6558F	IC	1	[W]
CN751	SJS305-1	CONNECTOR (3P)	1	[W]	1C501	BA6218	IC	1	[W]
CN752	RJS1A6503	CONNECTOR (3P)	1	[W]	1C511	UPC4570C	IC	1	[W]
CN901-05	RJU003K010W1	CONNECTOR (10P)	5	[W]	1C551, 52	UPC4570C	IC	2	[W]
CN1001, 02	RJU100W07	CONNECTOR (7P)	2	[W]	△ 1C601, 02	RSN3635A-P	IC	2	[W]
CP101, 02	RJT057W007-1	CONNECTOR (7P)	2	[W]	△ 1C603	RSN33M5-P	IC	1	[W]
CP401-05	RJT100W07	CONNECTOR (7P)	5	[W]	1C901	M30853M4053F	IC	1	[W]
CP501	RJT100W07	CONNECTOR (7P)	1	[W]	1C902	STK311-D10	IC	1	[W]
CP502	RJT100W04	CONNECTOR (4P)	1	[W]	1C1001	LA2786L	IC	1	[W]
CP771	RJP3G4YA	CONNECTOR (3P)	1	[W]	1C1002	LY1016L	IC	1	[W]
CP901-05	RJT003K010-1	CONNECTOR (10P)	5	[W]	1C1003	JC9214F	IC	1	[W]
CP1001, 02	RJT100W07	CONNECTOR (7P)	2	[W]	1C1004	TC9162AH	IC	1	[W]
					1C1151	UPC4570C	IC	1	[W]
△ D101	MA4051MTA	DIODE	1	[W]					
D102	MA165TA	DIODE	1	[W]	JK101	RJH4202	ANT TERMINAL	1	[W]
△ D351, 52	MTZJ5R6BTA	DIODE	2	[W]	JK351	SJFD7-5	VCR1 IN TERMINAL	1	[W]
D353, 54	RVD1SS133TA	DIODE	2	[W]	JK353	SJF3069-3N	TY, VCR, DVD JACK	1	[W]
△ D401	MTZJ7R5CTA	DIODE	1	[W]	JK354	SJF3069-16N	SURROUND TERMINAL	1	[W]
D403, 04	RVD1SS133TA	DIODE	2	[W]	JK401	SJF3068-7N	PHONO TERMINAL	1	[W]
D581-84	MTZJ3R0ATA	DIODE	4	[W]	JK402-04	SJF3069N	TAPE, DVD, VCR JACK	3	[W]
D585, 86	RVD1SS133TA	DIODE	2	[W]	JK405	SJFD7	SUB WOOFER	1	[W]
D601-03	SB360L6508	DIODE	3	[W]	JK406	SJF3068-7N	CD TERMINAL	1	[W]
D604	RVD1SS133TA	DIODE	1	[W]	JK601	RJR0054	SP TERMINAL	1	[W]
D605	MTZJ6R2BTA	DIODE	1	[W]	JK602	RJH5601	SP TERMINAL	1	[W]
D606-08	RVD1SS133TA	DIODE	3	[W]	JK603	RJR0054	SP TERMINAL	1	[W]
D611-13	SB360L6508	DIODE	3	[W]	△ JK794	SJS9231-1B	AC INLET	1	[W]
D621-28	MA167ATA	DIODE	8	[W]					
D631-38	MA167ATA	DIODE	8	[W]	L101	ELESN1R0MA	COIL	1	[W]
D654, 55	RVD1SS133TA	DIODE	2	[W]	L103	ELEXTA7MA9	COIL	1	[W]
D658-60	RVD1SS133TA	DIODE	3	[W]	L105, 06	RLQZB82XT-D	COIL	2	[W]
△ D701-04	P300DLF	DIODE	4	[W]	L151	SLM1B10M-1M	COIL	1	[W]
△ D705	MTZJ6R2BTA	DIODE	1	[W]	L191	ELESNR56MA	COIL	1	[W]
△ D707	MTZJ27DTA	DIODE	1	[W]	L501, 02	RLQZP1R0KT-Y	COIL	2	[W]
△ D708	MTZJ15CTA	DIODE	1	[W]	L601, 02	RLQYR73MW-E	COIL	2	[W]
△ D721-28	P300DLF	DIODE	8	[W]	L651, 52	RLQYR73MW-E	COIL	2	[W]
△ D751-54	ISR35200TB	DIODE	4	[W]	L671	RLQYR73MW-E	COIL	1	[W]
D755	RVD1SS133TA	DIODE	1	[W]	L751	RLQB101KTA-Y	COIL	1	[W]
△ D756	MTZJ6R8BTA	DIODE	1	[W]	△ L791	SLOZ650MS149	COIL	1	[W]
D771, 72	RVD1SS133TA	DIODE	2	[W]	L901	RLQB101KTA-Y	COIL	1	[W]
D773	MTZJ9R1CTA	DIODE	1	[W]	L902	RLQZP101KT-Y	COIL	1	[W]
D774	RVD1SS133TA	DIODE	1	[W]	L1051	RLQB101KTA-Y	COIL	1	[W]
D781, 82	RVD1SS133TA	DIODE	2	[W]					
D901	ISS291TA	DIODE	1	[W]	P1	RPN0966-1	PAD	1	[W]
D903	MTZJ4R7BTA	DIODE	1	[W]	P2	RPFX0005	MIRAMAT BAG	1	[W]
D908	MA167ATA	DIODE	1	[W]	P3	RPG3481	PACKING CASE	1	[W] (E)
D921	RVD1SS133TA	DIODE	1	[W]	P3	RPG3482	PACKING CASE	1	[W] (EB, EG)
D923	RVD1SS133TA	DIODE	1	[W]	P4	SPB1061	SHEET	1	[W]
△ D924	MTZJ3R9ATA	DIODE	1	[W]	P5	SPSD152	ACCESSORY BOX	1	[W]
D925	RVD1SS133TA	DIODE	1	[W]					
D929	LN846RP	LED	1	[W]	Q101	2SC2787LTA	TRANSISTOR	1	[W]
D930	SLR342DC	LED	1	[W]	Q103, 04	2SC2785FETA	TRANSISTOR	2	[W]
D936	SLR342WC	LED	1	[W]	Q106	UN411FTA	TRANSISTOR	1	[W]
△ D1001	MTZJ10CTA	DIODE	1	[W]	Q107, 08	2SC3311AR	TRANSISTOR	2	[W]
D1002	MA700ATA	DIODE	1	[W]	△ Q351	2SD592AQSTA	TRANSISTOR	1	[W]
					△ Q352	2SB621AQSTA	TRANSISTOR	1	[W]
E401	SNE1004-2	EARTH TERMINAL	1	[W]	Q401, 02	2SK381BCDTA	TRANSISTOR	2	[W]
E601	SNE1004-2	EARTH TERMINAL	1	[W]	Q481	2SD1915FTA	TRANSISTOR	1	[W]
△ F1	XBA2C25TBO	FUSE	1	[W]	Q501, 02	2SJ40CDDTA	TRANSISTOR	2	[W]
△ F3, F4	XBA2C63TBO	FUSE	2	[W]	Q505, 06	2SD1915FTA	TRANSISTOR	2	[W]
					Q551, 52	2SD1915FTA	TRANSISTOR	2	[W]
FC701, 02	EYF52BC	FUSE HOLDER	2	[W]	Q571, 72	2SA1309AQSTA	TRANSISTOR	2	[W]
FC705-08	EYF52BC	FUSE HOLDER	4	[W]	Q573, 74	2SC3311AQSTA	TRANSISTOR	2	[W]
					Q575	2SA1309AQSTA	TRANSISTOR	1	[W]
FL901	RSL0233-F	FL	1	[W]	Q576	2SC3311AQSTA	TRANSISTOR	1	[W]
					Q581, 82	2SA1309AQSTA	TRANSISTOR	2	[W]
HP601	RJJ63TA01	HP JACK	1	[W]	Q583, 84	2SC3311AQSTA	TRANSISTOR	2	[W]
					Q585, 86	2SA1309AQSTA	TRANSISTOR	2	[W]
1C101	LA1832A	IC	1	[W]	Q601-03	DTA113ZSATP	TRANSISTOR	3	[W]
1C102	LC7218	IC	1	[W]	Q609	DTC114ES	TRANSISTOR	1	[W]
1C351	NJM2279D	IC	1	[W]	Q610	DTC114TS	TRANSISTOR	1	[W]
1C352	AN6554F	IC	1	[W]	Q611, 12	2SC3311AQSTA	TRANSISTOR	2	[W]
1C401	TC9163AH	IC	1	[W]	Q681, 82	2SD1915FTA	TRANSISTOR	2	[W]
1C402	UPC4570C	IC	1	[W]	△ Q701	2SD2374PQAU	TRANSISTOR	1	[W]
					△ Q703-05	2SC3311AQSTA	TRANSISTOR	3	[W]
					△ Q706	2SC3940AQSTA	TRANSISTOR	1	[W]

■ Packaging

Ref. No.	Part No.	Part Name & Description	Pcs	Remarks
R1051	ERDS2TJ393T	1/4W 39K	1	[M]
R1052	ERDS2FJ105	1/4W 1M	1	[M]
R1053	ERDS2TJ102T	1/4W 1K	1	[M]
R1055	ERDS2FJ224	1/4W 220K	1	[M]
R1056	ERDS2TJ153T	1/4W 15K	1	[M]
R1061	ERDS2TJ222T	1/4W 2.2K	1	[M]
R1062	ERDS2TJ273T	1/4W 27K	1	[M]
R1063	ERDS2TJ332T	1/4W 3.3K	1	[M]
R1151, 52	ERDS2TJ473T	1/4W 47K	2	[M]
R1154	ERDS2TJ273T	1/4W 27K	1	[M]
R1155, 56	ERDS2TJ393T	1/4W 39K	2	[M]
R1158	ERDS2TJ104T	1/4W 100K	1	[M]
R1160	ERDS2TJ104T	1/4W 100K	1	[M]
R469, 70	ERDS2TJ102T	1/4W 1K	2	[M] (E)
△ RL601-04	RSY0013W-0	RELAY	4	[M]
△ RL751	RSY0019W-0	RELAY	1	[M]
S946	EVQ21405R	SW	1	[M]
S948	EVQ21405R	SW	1	[M]
S950-58	EVQ21405R	SW	9	[M]
S965	EVQ21405R	SW	1	[M]
S970-76	EVQ21405R	SW	7	[M]
S980-85	EVQ21405R	SW	6	[M]
S991-96	EVQ21405R	SW	6	[M]
△ T701	RTP1Q5B003-V	POWER TRANSFORMER	1	[M]
△ T751	RTP115E006	POWER TRANSFORMER	1	[M]
YR401-03	EVUE3AE20B15	VOLUME	3	[M]
YR501	EUWM6A026B15	VOLUME	1	[M]
YR502	EWCOYAF15G15	VOLUME	1	[M]
YR511, 12	EWCTXA016C15	VOLUME	2	[M]
X101	RSXZ456KW07M	OSCILLATOR	1	[M]
X102	RLFDGT0011	OSCILLATOR	1	[M]
X103	SVQ49U722T-S	OSCILLATOR	1	[M]
Z101	RLA22002W-T	COMPONENT COMBINATION	1	[M]
Z102	RL122006W-T	COMPONENT COMBINATION	1	[M]
Z120	ENV17290G1R	FM FRONT END	1	[M]
△ Z751	ERZV10V511CS	COMPONENT COMBINATION	1	[M]
Z891	RCDSPS4242R	REMOTE SENSOR	1	[M]

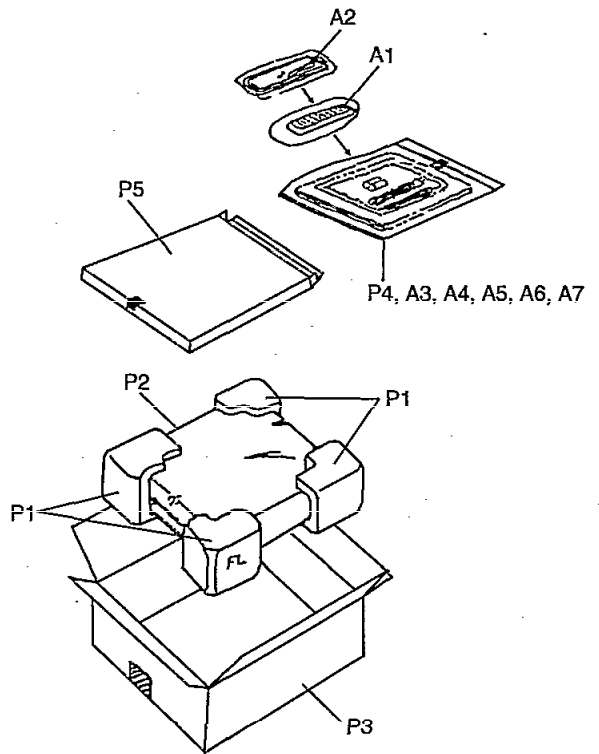

■ Cabinet Parts Location

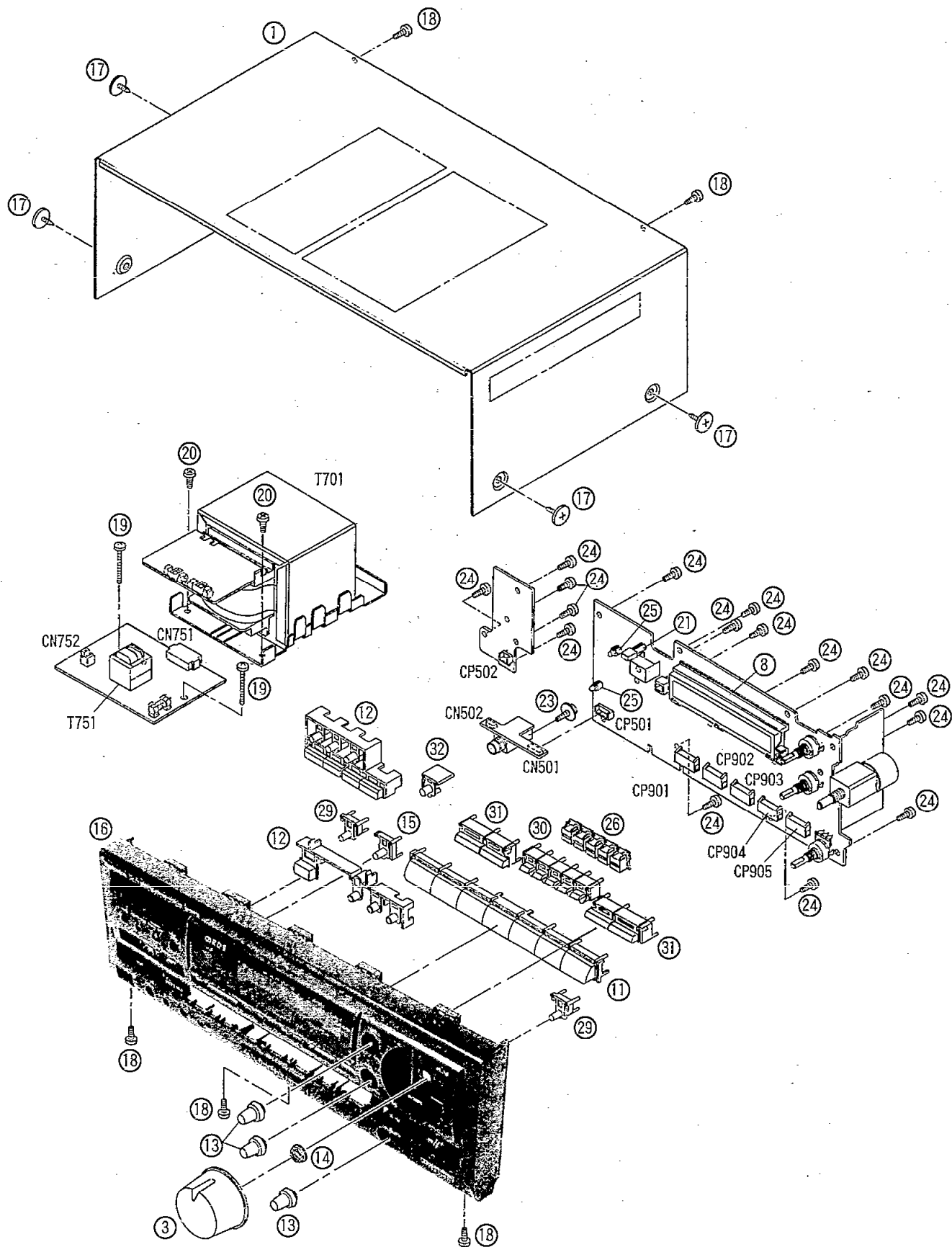

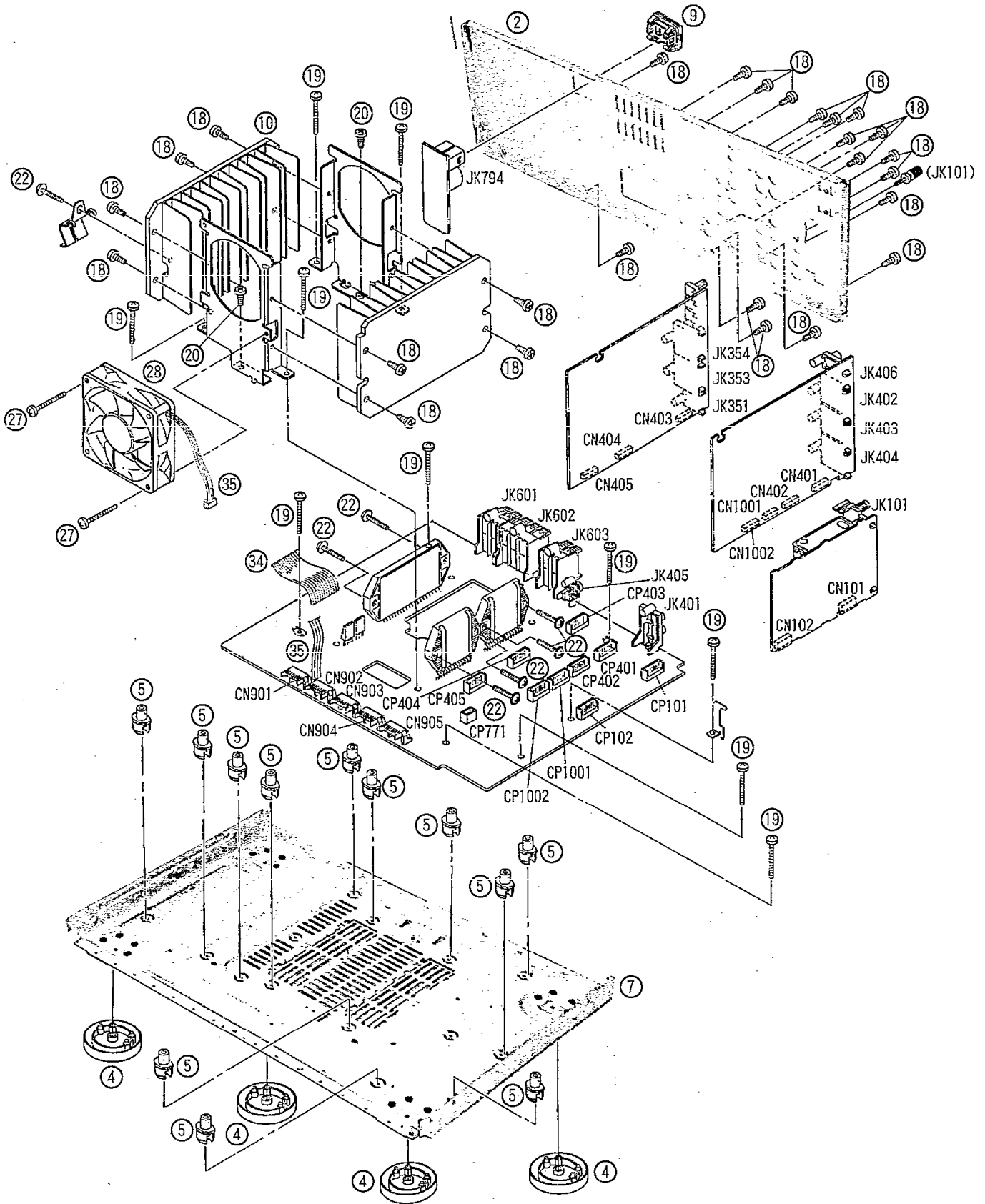

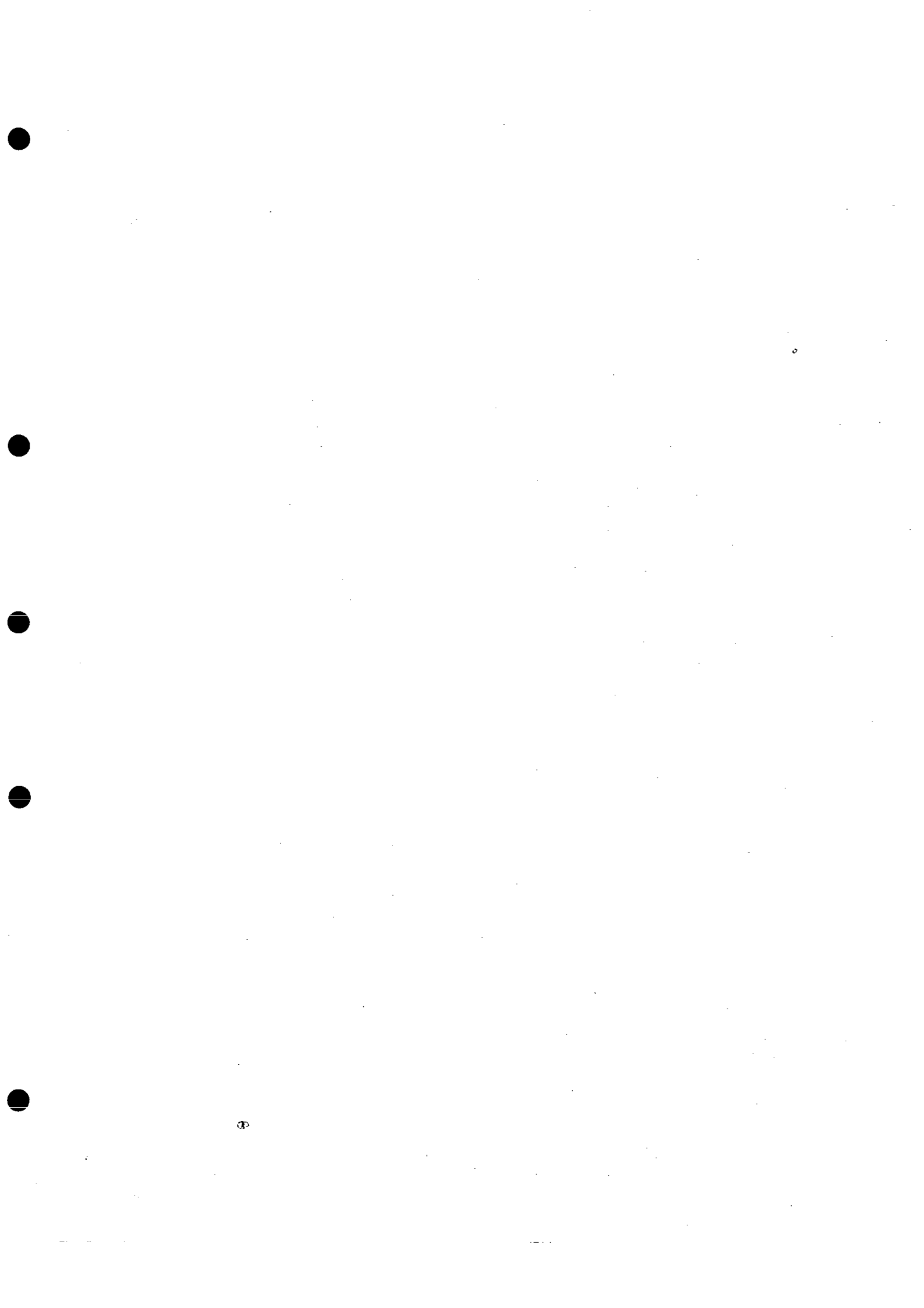

371